

OEM GROUP

PRODUCT DIRECTORY

EDITION 1.5



YOUR PARTNER IN **PRODUCTIVITY.**

OEM

GROUP



OVER 40 YEARS INDUSTRY EXPERIENCE

OUR MISSION

To optimise the productivity of our clients partnering with superior products, service and design with safety at the forefront.



**ENGINEERING
SOLUTIONS**



**INNOVATION &
CREATIVITY**



**CONTINUOUS
IMPROVEMENT**



**PROCESS
DRIVEN**



**OPTIMISE
PRODUCTIVITY**



**ENHANCE
ON-SITE SAFETY**



**CUSTOM
DESIGN**



RESOURCEFUL



WHO WE ARE

For more than 40 years, OEM Group has been the exclusive distributors for a wide range of prefabricated products and innovative industrial equipment. We work with many companies involved in mining, civil, oil, gas, marine, aviation, transport and industrial sectors. Founded in Perth, Western Australia, OEM Group is proudly West Australian owned and operated so we understand the unique needs of our large state and country.

OEM Group is very proud to be the exclusive WA Distributors for Spitwater and Jetfire, and manufacturers of Steprite, Jackrite and WestChock.

Our innovative products are built to optimise and maximise productivity, and improve safety of all our clients. They all meet and exceed the Australian standards of the highest quality. Each of these high-quality brands have a diverse range of products to suit any job. If you cannot find a suitable product, we can tailor make it for you.

Our team of expert technicians can service and repair all brands of pressure cleaner, space heater or industrial vacuums at our workshop in Perth or onsite, and our mobile units can also come to you.

If you require a tailor-made engineering solution, our team of skilled fabricators can design and build fit-for-purpose, custom designs, and industrial equipment.

OEM Group specialises in aluminium welding and fabrication and can create an innovative design or equipment to suit your every need.

We commit ourselves to creating custom solutions that slash your downtime cost, improve safety, maximise your performance and optimise your productivity to the highest level. If there is a safer and more productive way to do the job, we will find it.

OEM promises to deliver to our clients:

- Reduced downtime costs
- Enhance on-site safety
- Optimise their performance
- Improve Productivity

SOME OF OUR CLIENTS WE PARTNER IN PRODUCTIVITY WITH

RioTinto

AUSTRALIAN MINES
LIMITED

THIESS

BHP

 Newmont™

KOMATSU

Westrac 

Downer 

 FMG Fortescue

Barminto

TOLL

 AUSDRILL



CONTENTS

01

FIXED PLANT SOLUTIONS

Safety Access Platforms	10
Custom Projects	26
Diacon Conveyor Guarding and Anti Spillage systems	30

02

MOBILE EQUIPMENT SOLUTIONS

Mining Truck	34
Excavator	58
Loader	60
Dozer	72
Recovery Trailer	80

03

WORKSHOP SOLUTIONS

Storage	84
Stands	86
Racking	96
Benches	98
Shelving	100
Wheel Chocks - Westchock	102



04

SAFETY ACCESS SOLUTIONS

STEPRITE®	106
Aviation	110
Locomotive	118
Crane	120
Oil & Gas	122
Transport	126
Wash Down Bay Platforms	127

05

INDUSTRIAL CLEANING SOLUTIONS

Industrial Pressure Cleaners - <i>Spitwater</i>	130
Industrial Heaters - <i>Jetfire</i>	146
Industrial Vacuum Cleaners - <i>Vacstorm</i>	150
Industrial Floor Scrubbers	153
Mounted Pressure Cleaners - Trailers, Trucks & Utes	154
Tailor-Made Cleaning Solutions	157
Ultra High Pressure Cleaner Training	159

06

SPECIALISED SERVICES

Onsite 3D Scanning	162
Asset Management	164
Service & Repair	166
Long or Short Term Hire	168
Customised Projects	170

*Flip the book
sideways to easily
navigate to your section*



01

FIXED PLANT SOLUTIONS

Safety Access Platforms	10 - 25
Custom Projects	26 - 29
Diacon Conveyor Guarding and Anti Spillage systems	30 - 31



SAFETY ACCESS PLATFORMS

Train Loadout Platforms

Train Loadout Safety Side Entry Access Platform

- Anti-slip stairway and work area
- Safety handrails
- Self-closing gates
- Lockable swivel wheels
- Jockey stand

Construction: Aluminum

Height: 1130mm

WLL: 250kg



Part No: OEM00594

Train Loadout Safety End Access Platform

- Anti-slip stairway and work area
- Safety handrails
- Self-closing gates
- Lockable swivel wheels
- Tool tray

Construction: Aluminum

Height: 2000mm

WLL: 250kg



Part No: OEM00189

Train Loadout Safety Access Platform Fixed

- Anti-slip stairway and work area
- Safety handrails
- Self-closing gates

Construction: Aluminum

Height: 2800mm

WLL: 250kg



Part No: OEM00194

SAFETY ACCESS PLATFORMS

Train Loadout Platforms



Can't find what you want?
Contact us at
+61 8 9270 0200 or
contactoem@oemgroup.com.au

Train Loadout Height Access Platform

- Anti-slip stairway and work area
- Safety handrails
- Self-closing gates
- Lockable swivel wheels
- Tool tray

Construction: Aluminum

Height: 3250mm

WLL: 250kg



Part No: OEM00190

Train Loadout Inspection Safety Access Platform

- Anti-slip stairway and work area
- Safety handrails
- Lockable swivel wheels
- Overhang
- Tool tray

Construction: Aluminum

Height: 2000mm

WLL: 250kg



Part No: OEM00350

OEM01547 - Crusher Bowl Assembly Platform



Made in WA TO AUSTRALIAN STANDARDS

SAFETY ACCESS PLATFORMS

Reclaimer Platforms

Reclaimer Side Safety Access Platform

- Anti-slip stairway and work area
- Safety handrails

Construction: Aluminum

Height: 415mm

WLL: 250kg



Part No: OEM00227

Reclaimer Wheel Inspection Platform

- Anti-slip stairway and work area
- Safety handrails
- 4-Point Access

Construction: Aluminum

Height: 710mm

WLL: 250kg



Part No: OEM00157

Reclaimer 2-Tier Safety Access Platform

- Anti-slip stairway and work area
- Safety handrails
- Self-closing gates
- Lockable swivel wheels
- Gate

Construction: Aluminum

Height: 4700mm

WLL: 250kg



Part No: OEM00378

SAFETY ACCESS PLATFORMS

Reclaimer Platforms



Can't find what you want?
Contact us at
+61 8 9270 0200 or
contactoem@oemgroup.com.au

Reclaimer Bucket Wheel Safety Access Platform

- Anti-slip stairway and work area
- Safety handrails
- Lockable swivel wheels
- Forklift pockets
- Gate
- Jacking stand

Construction: Aluminum

WLL: 250kg



Part No: OEM00554

Reclaimer Bucket Safety Access Platform

- Anti-slip stairway and work area
- Safety handrails
- Lockable swivel wheels
- Overhang
- Gate
- Counterweight

Construction: Aluminum

WLL: 250kg



Part No: OEM00558

Chute Platforms

3 Point Safety Access Platform

- Anti-slip stairway and work area
- Safety handrails
- Self-closing gates
- Lockable swivel wheels
- Forklift pockets
- Gate
- Jockey stand
- Counterweight

Construction: Aluminum

Height: 3050mm

WLL: 250kg



Part No: OEM00276

SAFETY ACCESS PLATFORMS

Chute Platforms



Can't find what you want?
Contact us at
+61 8 9270 0200 or
contactoem@oemgroup.com.au

Chute Inspection Safety Access Platform

- Anti-slip stairway and work area
- Safety handrails
- Lockable swivel wheels
- Forklift pockets
- Gate

Construction: Aluminum

WLL: 250kg



Part No: OEM00398

Chute Cover Safety Access Platform

- Anti-slip stairway and work area
- Safety handrails
- Gate
- Ladder cage

Construction: Aluminum

WLL: 250kg



Part No: OEM00416

Hydraulic Adjustable Platform

- Anti-slip stairway and work area
- Self-closing gates
- Safety handrails
- Lockable swivel wheels
- Forklift pockets
- Manual over hydraulic

Construction: Aluminum

Forklift Slots: Yes

WLL: Various



Part No: OEM01032



STEPRITE
MULTI-LEVEL ACCESS SOLUTIONS

C/O General
Brisbane

OEM GROUP Phone: 1800 783 774
www.oemgroup.com.au

WARNING
WATCH FACE
KEEP CLEAR OF
END OF TRAVEL
STOP SIGNALS
BEFORE REACHED

WARNING
KEEP CLEAR
OF OVERHEAD
PLATFORM

**YOUR SAFETY
IS OUR PRIORITY**

SAFETY ACCESS PLATFORMS

Conveyor Platforms

Conveyor Feed Safety Access Platform

- Anti-slip stairway and work area
- Safety handrails
- Lockable swivel wheels
- Forklift pockets
- Overhang
- Gate
- Jacking stand

Construction: Aluminum

WLL: 250kg



Part No: OEM00409

Drum Platforms

Drum Safety Access Platform

- Anti-slip stairway and work area
- Safety handrails
- Self-closing gates
- Lockable swivel wheels

Construction: Aluminum

Height: 2500mm

WLL: 250kg



Part No: OEM00159

Drum Floater Sink Screen Safety Access Platform

- Anti-slip stairway and work area
- Safety handrails
- Self-closing gates
- Lockable swivel wheels
- Overhang
- Counterweight
- Boom arm

Construction: Aluminum

WLL: 250kg



Part No: OEM00170

SAFETY ACCESS PLATFORMS

Vibrating Platforms



Vibrating Feeder Safety Access Platform

- Anti-slip stairway and work area
- Safety handrails
- Lockable swivel wheels
- Gate
- Chain

Construction: Aluminum

Height: 1250mm

WLL: 250kg



Part No: OEM00647

Vibrating Screen Safety Access Platform

- Anti-slip stairway and work area
- Safety handrails
- Self-closing gates
- Lockable swivel wheels
- Additional handrail

Construction: Aluminum

Height: 2400mm

WLL: 250kg



Part No: OEM00366

Vibrating Screen Side Safety Access Platform

- Anti-slip stairway and work area
- Safety handrails
- Self-closing gates
- Lockable swivel wheels
- Gate
- Tool tray

Construction: Aluminum

WLL: 250kg



Part No: OEM00374

SAFETY ACCESS PLATFORMS

Vibrating Platforms

Chute Feeder Platform

- Anti-slip stairway and work area
- Safety handrails
- Lockable swivel wheels
- Gate

Construction: Aluminum

WLL: 250kg

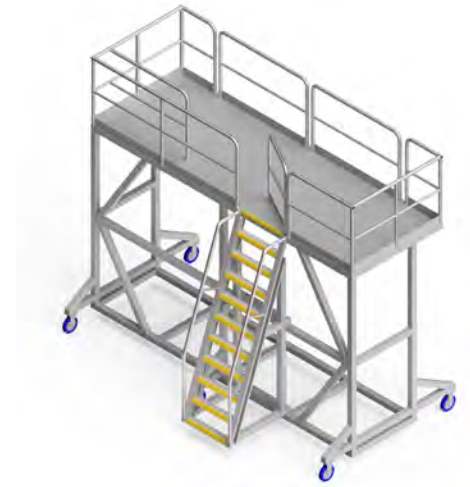

Part No: OEM00072

Belt Splice Platforms

Belt Splicing Safety Access Platform

- Anti-slip stairway and work area
- Safety handrails
- Ladder cage
- Boom arm

Construction: Aluminum

Height: 862mm - 1150mm

WLL: 250kg

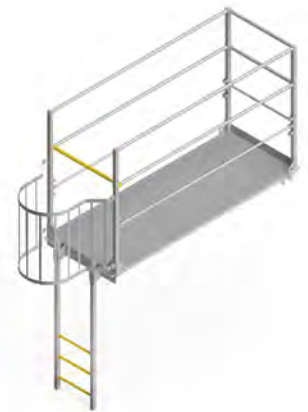

Part No: OEM00570

Belt Splice Safety Access Platform

- Anti-slip stairway and work area
- Safety handrails

Construction: Aluminum

WLL: 250kg



Part No: OEM00414

SAFETY ACCESS PLATFORMS

Crusher Platforms



Can't find what you want?
Contact us at
+61 8 9270 0200 or
contactoem@oemgroup.com.au

Crusher Safety Access Platform

- Anti-slip stairway and work area
- Safety handrails
- Self-closing gates
- Lockable swivel wheels
- Counterweight
- Ladder

Construction: Aluminum

Height: 2148mm

WLL: 250kg



Part No: OEM01344

Crusher Mantle Safety Access Platform

- Anti-slip stairway and work area
- Safety handrails
- Self-closing gates
- Lockable swivel wheels
- Overhang
- Counterweight

Construction: Aluminum

WLL: 250kg



Part No: OEM00641

Crusher Hydroset Oil Tank Safety Access Platform

- Anti-slip stairway and work area
- Safety handrails
- Self-closing gates
- Lockable swivel wheels
- Jacking stand

Construction: Aluminum

WLL: 250kg



Part No: OEM00642

SAFETY ACCESS PLATFORMS

Crusher Platforms



Can't find what you want?
Contact us at
+61 8 9270 0200 or
contactoem@oemgroup.com.au

Crusher Hydroset Oil Tank Safety Access Platform

- Anti-slip stairway and work area
- Safety handrails
- Self-closing gates
- Lockable swivel wheels
- Jacking stand

Construction: Aluminum

WLL: 250kg



Part No: OEM00643

Various Platforms

Car Dumper Safety Access Platform

- Anti-slip stairway and work area
- Safety handrails
- Lockable swivel wheels
- Gate

Construction: Aluminum

Height: 2500mm

WLL: 250kg



Part No: OEM00155

LRP Safety Access Platform

- Anti-slip stairway and work area
- Safety handrails
- Self-closing gates
- Lockable swivel wheels

Construction: Aluminum

Height: 2000mm

WLL: 250kg



Part No: OEM00156



**INNOVATIVE
INDUSTRIAL
EQUIPMENT**

Made in WA TO AUSTRALIAN STANDARDS

SAFETY ACCESS PLATFORMS

Various Platforms

Cyclone Screen Safety Access Platform

- Anti-slip stairway and work area
- Safety handrails
- Self-closing gates
- Lockable swivel wheels
- Overhang
- Counterweight
- Boom arm

Construction: Aluminum

Height: 1450mm

WLL: 250kg



Part No: OEM00171

Feeder Safety Access Platform

- Anti-slip stairway and work area
- Safety handrails
- Lockable swivel wheels

Construction: Aluminum

Height: 2355mm

WLL: 250kg



Part No: OEM00503

Screen Plant Safety Access Platform

- Anti-slip stairway and work area
- Safety handrails
- Lockable swivel wheels
- Forklift pockets
- Overhang
- Gate
- Counterweight

Construction: Aluminum

Height: 3200mm

WLL: 250kg



Part No: OEM00399

SAFETY ACCESS PLATFORMS

Various Platforms



Mantle Safety Access Platform

- Anti-slip stairway and work area
- Safety handrails
- Self-closing gates
- Lockable swivel wheels
- Overhang

Construction: Aluminum

WLL: 250kg



Part No: OEM00339

Scalping Screen Safety Access Platform

- Anti-slip stairway and work area
- Safety handrails
- Lockable swivel wheels
- Gate

Construction: Aluminum

WLL: 250kg



Part No: OEM00563

Chute Plug

- Anchor points

Construction: Steel

WLL: N/A

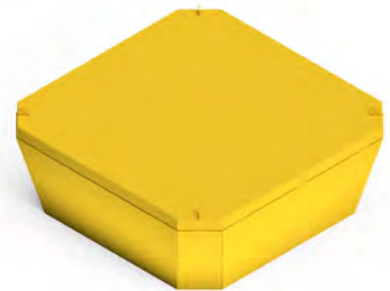

Part No: OEM00091

SAFETY ACCESS PLATFORMS

Various Platforms

Secondary Crusher Bowl Safety Access Platform

- Anti-slip stairway and work area
- Safety handrails
- Self-closing gates
- Lockable swivel wheels
- Overhang
- Gate
- Counterweight

Construction: Aluminum

WLL: 250kg



Part No: OEM00650

Hydroset Safety Access Platform

- Anti-slip stairway and work area
- Safety handrails
- Self-closing gates
- Lockable swivel wheels
- Overhang

Construction: Aluminum

WLL: 250kg



Part No: OEM00655

Ship Loader Scraper Safety Access Platform

- Anti-slip stairway and work area
- Safety handrails
- Self-closing gates
- Lockable swivel wheels

Construction: Aluminum

WLL: 250kg



Part No: OEM01044

SAFETY ACCESS PLATFORMS

Various Platforms



Product Feeder Safety Access Platform

- Anti-slip stairway and work area
- Safety handrails
- Lockable swivel wheels
- Overhang
- Gate

Construction: Aluminum

WLL: 250kg



Part No: OEM00560

Product Screen Rollout Chute Safety Access Platform

- Anti-slip stairway and work area
- Safety handrails

Construction: Aluminum

WLL: 250kg



Part No: OEM00536

Chute Screen Platform

- Anti-slip stairway and work area
- Safety handrails
- Self-closing gates
- Lockable swivel wheels
- Overhang
- Tool tray

Construction: Aluminum

WLL: 250kg



Part No: OEM00151

CUSTOM PROJECTS

Access Platforms

Sizer Maintenance Safety Access Platform

- Anti-slip stairway and work area
- Safety handrails
- Overhead roof

Construction: Aluminum

WLL: 1500kg



Part No: OEM01049

Vibrating Screen Wear Liner Change Out Safety Access Platform

- Anti-slip stairway and work area
- Safety handrails

Construction: Aluminum

WLL: 1500kg



Part No: OEM01299

Chute Liner Maintenance Platform

- Anti-slip stairway and work area
- Safety handrails
- Multi-level with hatch

Construction: Aluminum

WLL: 1500kg

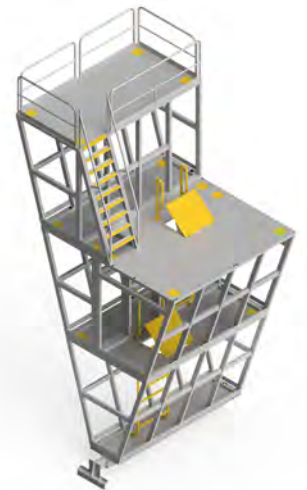

Part No: OEM00152

CUSTOM PROJECTS

Access Platforms



Can't find what you want?
Contact us at
+61 8 9270 0200 or
contactoem@oemgroup.com.au

Cone Crusher Head Assembly Platform

Construction: Steel
Height: 1800mm
WLL: 20T

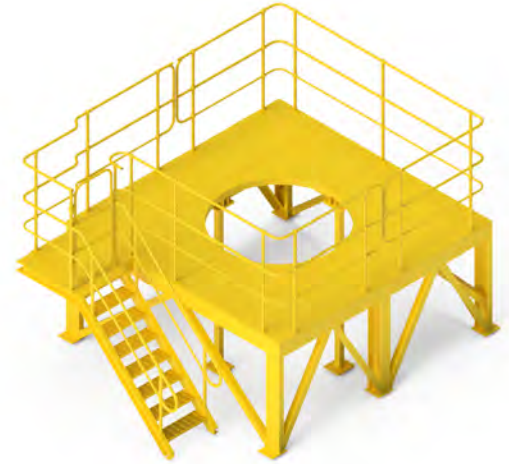

Part No: OEM01547

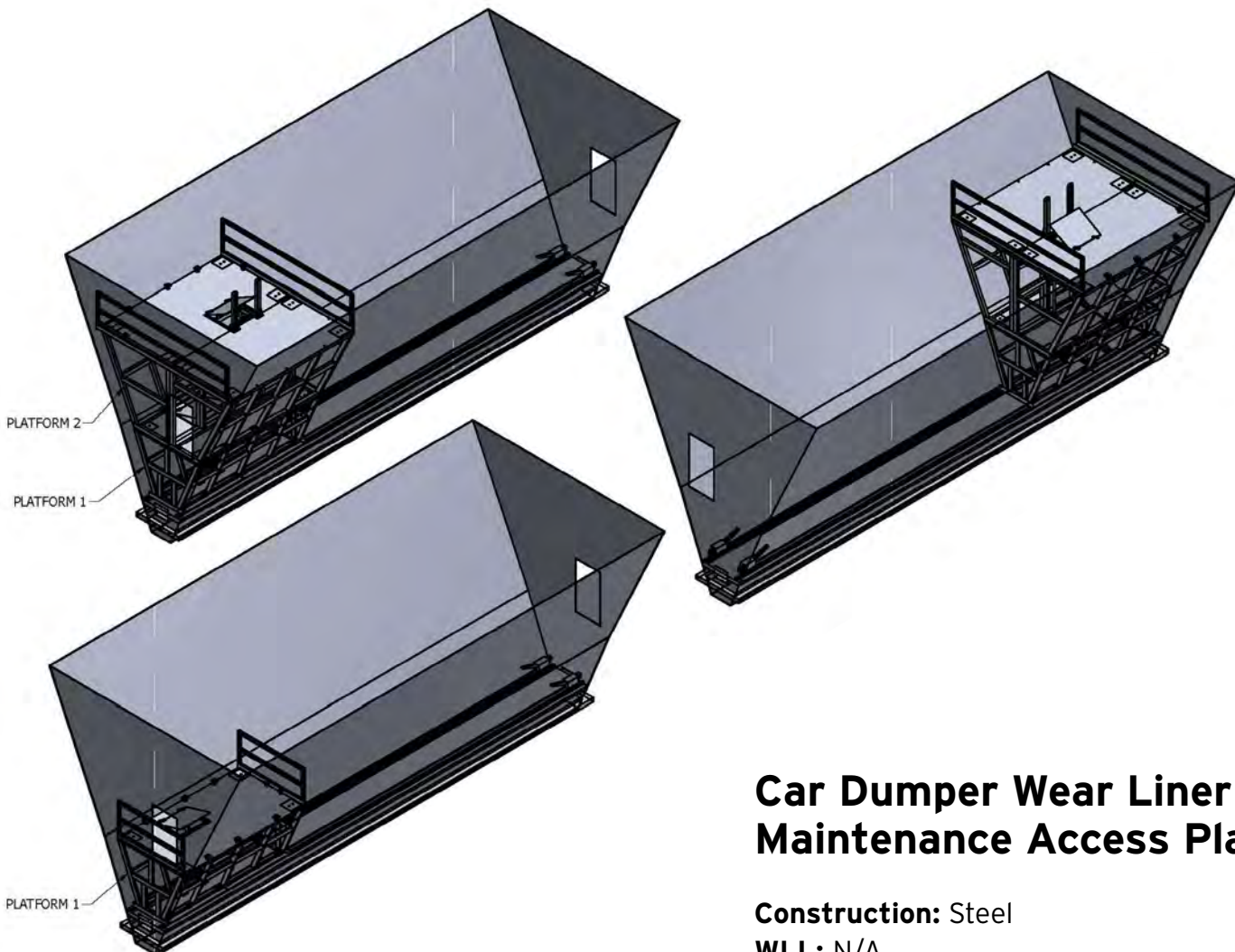

Car Dumper Wear Liner Maintenance Access Platform

Construction: Steel
WLL: N/A

Part No: OEM01587

CUSTOM PROJECTS

Conveyor Specific

Return Idler Change Out Safety Access Platform

Construction: Aluminum
WLL: 250kg

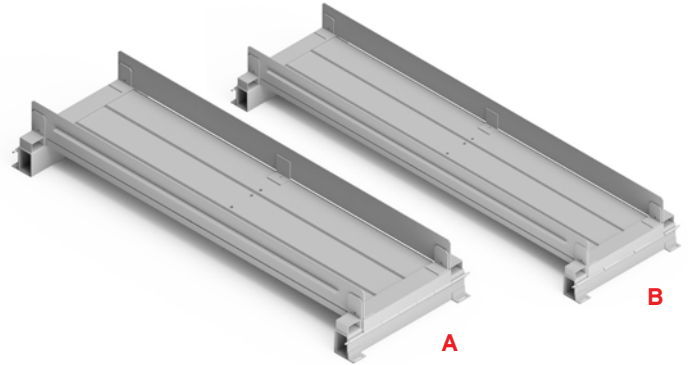

Part No: OEM00459

Belt Splicing Handrails and Roof Cover

- Anti-slip stairway and work area
- Safety handrails

Construction: Aluminum
WLL: 250kg



Part No: OEM00682

Belt Splicing Platform

Construction: Aluminum
WLL: 250kg



Part No: OEM00872

Vibrating Screen Tile Box

- Anchor points

Construction: Aluminum
WLL: 250kg

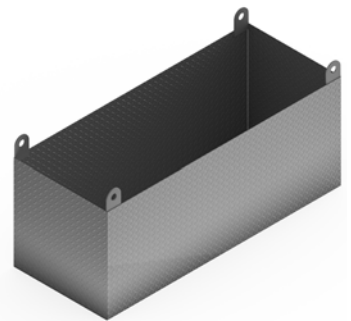

Part No: OEM01161

CUSTOM PROJECTS

Conveyor Specific



Can't find what you want?
Contact us at
+61 8 9270 0200 or
contactoem@oemgroup.com.au

Conveyor Roller Trolley

- Fixed pneumatic wheels

Construction: Aluminum
WLL: 250kg



Part No: OEM00490

Conveyor Roller Trolley

- Forklift pockets

Construction: Aluminum
WLL: 250kg



Part No: OEM00789

Conveyor Roller Trolley

- Anti-slip deck
- Fixed pneumatic wheels with break

Construction: Aluminum
Height: 360mm
WLL: 100kg



Part No: OEM00225

Harvester Belt Lifter

Construction: Steel
WLL: 250kg



Part No: OEM00791

Roller Changeout Storage Cabinet

- Forklift pockets

Construction: Steel
WLL: 650kg



Part No: OEM01316

Magnet Trolley

- Ø850 wheels

Construction: Steel
WLL: 20,000kg



Part No: OEM01042

DIACON CONVEYOR GUARDING & ANTI SPILLAGE SYSTEMS



Diacon System

Diacon Conveyor Hungry Board

The DIACON hungry Board is an aluminum-reinforced, plastic panel that is used on conveyor belts to contain products, reduce spillage and increase conveyor capacity by up to 30%. From greenfield sites to existing plant upgrades, DIACON is your low cost, corrosion free, lightweight and easy to install alternative.

Diacon Conveyor Guard

The DIACON Conveyor Guard is a plastic mesh, conveyor guarding system which improves safety in the materials handling industry. Complementing the DIACON Hungry Board, this corrosion free and lightweight guard requires no painting, is easily installed and allows for quick guard removal during maintenance operations. This product can be configured to meet individual needs.

Diacon Safety Panel

The DIACON Safety Panel is a plastic mesh guarding system configurable to protect operators and maintenance personnel in factories and process plants. This product can be used for guarding of conveyor nip points, transmission elements, workshop equipment, hazard demarcation areas and can provide general risk reduction around machinery and working at heights.



All DIACON products are designed to meet or exceed the requirements of Australian Standards AS4024.1-2006, AS1755-2000

STEP 1

Bolt mounting bracket to existing troughing roller frame

STEP 2

Attach hungry boards to the bracket with locking wedge

STEP 3

“Hook, Hang and Lock” the safety guard panel to the bracket



Product Benefits

- Lightweight and easy to remove
- 100% corrosion free, no need to paint
- Easily configurable into a variety of shapes
- Mount using drop on “hook and hang” system
- Panel guard can hang on nearby handrail when removed
- Panel weight is marked on guard
- Provides long life UV protection
- Meets Australian standards
- Safe during operations and maintenance periods

02

MOBILE EQUIPMENT SOLUTIONS

Mining Truck	34 - 57
Excavator	58 - 59
Loader	60 - 71
Dozer	72 - 79
Recovery Trailer	80 - 81



MINING TRUCK

Stands, Accessories & Tools

Designs available to suit all Makes & Models

Hub Stand MODEL A

- Forklift pockets
- Castor wheels
- Self raising

Construction: Steel
WLL: 80T



Part No: OEM00735

Hub Stand MODEL B

- Forklift pockets
- Self raising

Construction: Steel
WLL: 100T



Part No: OEM00897

Radiator Stand

Construction: Steel
Height: 800mm
WLL: 20T



Part No: OEM00946

Fuel Tank Removal Tool

Construction: Steel
WLL: 5T



Part No: OEM00245

Mining Truck Tray Chock

Construction: Steel
WLL: 30T



Part No: OEM00790

Steer Cylinder Lifting Jig

Construction: Steel
WLL: 2T



Part No: OEM01057

MINING TRUCK

Stands, Accessories & Tools

Designs available to suit all Makes & Models



Can't find what you want?
Contact us at
+61 8 9270 0200 or
contactoem@oemgroup.com.au

Tray Lifting Tool



Construction: Steel
WLL: 40T

Part No: OEM00303

Tray Transporter



Construction: Steel
WLL: 40T

Part No: OEM01349



OEM01349 - Tray Transporter

MINING TRUCK

Handrails

Designs available to suit all Makes & Models

Chassis Handrail MODEL A

- Safety handrails

Construction: Aluminum

WLL: N/A



Part No: OEM00845

Chassis Handrail MODEL B

- Safety handrails

Construction: Aluminum

WLL: N/A

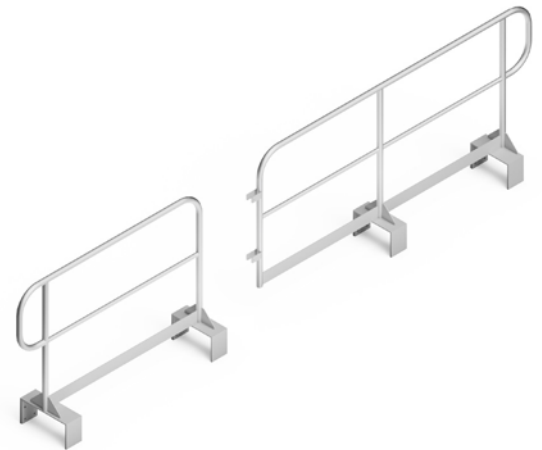

Part No: OEM00846

Chassis Handrail MODEL C

- Safety handrails

Construction: Aluminum

WLL: N/A



Part No: OEM01068

MINING TRUCK

Handrails

Designs available to suit all Makes & Models



Chassis Handrail MODEL D

- Safety handrails

Construction: Aluminum

WLL: N/A



Part No: OEM00880

Chassis Handrail MODEL E

- Safety handrails

Construction: Aluminum

WLL: N/A

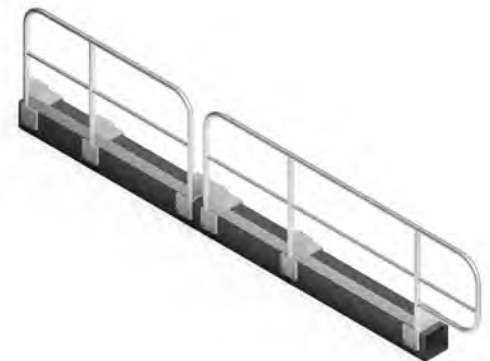

Part No: OEM00522

Chassis Access Platform

- Anti-slip stairway and work area
- Safety handrails
- Self-closing gates
- Lockable swivel wheels
- Overhang

Construction: Aluminum

WLL: 250kg



Part No: OEM00853

MINING TRUCK

Access Platforms

Designs available to suit all Makes & Models

Right Hand Air Cleaner Access Platform MODEL A

- Anti-slip stairway and work area
- Safety handrails
- Self-closing gates
- Lockable swivel wheels

Construction: Aluminum

Height: 2400mm

WLL: 250kg



Part No: OEM00396

Single Air Cleaner Access Platform MODEL B

- Anti-slip stairway and work area
- Safety handrails
- Self-closing gates
- Lockable swivel wheels
- Forklift pockets

Construction: Aluminum

Height: 2900mm

WLL: 250kg



Part No: OEM00499

Left Hand Air Cleaner Access Platform MODEL C

- Anti-slip stairway and work area
- Safety handrails
- Jacking stand
- Wheels

Construction: Aluminum

WLL: 250kg



Part No: OEM00857

MINING TRUCK

Access Platforms

Designs available to suit all Makes & Models



Double Entry Air Cleaner Access Platform MODEL D

- Anti-slip stairway and work area
- Self-closing gates
- Lockable swivel wheels
- Forklift pockets
- Overhang
- Jacking stand

Construction: Aluminum

WLL: 250kg



Part No: OEM00329

Air Cleaner Safety Access Platform with Lift

- Anti-slip stairway and work area
- Safety handrails
- Self-closing gates
- Lockable swivel wheels
- Air cleaner lift

Construction: Aluminum

Height: 2900mm

WLL: 250kg



Part No: OEM01483

Accumulator Safety Access Platform

- Anti-slip stairway and work area
- Safety handrails
- Lockable swivel wheels
- Forklift pockets
- Overhang
- Counterweight

Construction: Aluminum

WLL: 250kg



Part No: OEM01297

MINING TRUCK

Access Platforms

Designs available to suit all Makes & Models



Brake Cooling Hose Platform

- Anti-slip stairway and work area
- Safety handrails
- Forklift pockets
- Overhang
- Gate
- Jacking stand
- Wheels

Construction: Aluminum

WLL: 250kg



Part No: OEM00687

Rear Brake Access Platform

- Anti-slip stairway and work area
- Safety handrails
- Lockable swivel wheels

Construction: Aluminum

WLL: 250kg



Part No: OEM01403

GPS Calibration Safety Access Platform

- Anti-slip stairway and work area
- Safety handrails
- Multi-level construction

Construction: Aluminum

WLL: 250kg



Part No: OEM01254



WE OPTIMISE
PRODUCTIVITY

Made in WA TO AUSTRALIAN STANDARDS

MINING TRUCK

Access Platforms

Designs available to suit all Makes & Models



Engine Bay Safety Access Platform MODEL A

- Safety handrails
- Forklift pockets
- Jockey stand
- Gate

Construction: Aluminum

WLL: 250kg



Part No: OEM00354

Engine Bay Extended Safety Access Platform MODEL B

- Safety handrails
- Forklift pockets
- Jockey stand
- Gate

Construction: Aluminum

Height: 200mm to top of deck

WLL: 250kg



Part No: OEM00539

Fuel Tank Safety Access Platform

- Anti-slip stairway and work area
- Safety handrails
- Self-closing gates
- Lockable swivel wheels
- Forklift pockets
- Overhang
- Counterweight

Construction: Aluminum

WLL: 250kg



Part No: OEM01198



**SAFETY ACCESS
PLATFORMS
TO SUIT EVERY NEED**

Made in WA TO AUSTRALIAN STANDARDS

MINING TRUCK

Access Platforms

Designs available to suit all Makes & Models

Mining Truck Tray 2-Point Inspection Tray Safety Access Platform

MODEL A

- Anti-slip stairway and work area
- Safety handrails
- Self-closing gates
- Forklift pockets
- Wheels

Construction: Aluminum

WLL: 250kg

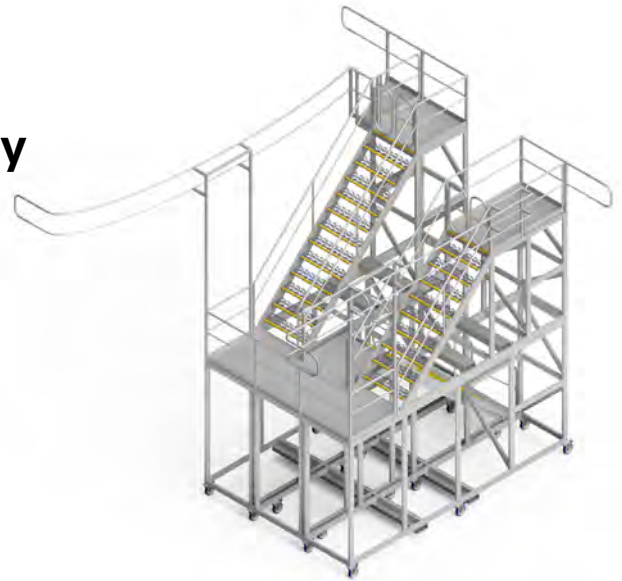

Part No: OEM01039

Mining Truck Tray Safety Access Platform

MODEL B

- Anti-slip stairway and work area
- Safety handrails
- Self-closing gates
- Lockable swivel wheels
- Forklift pockets

Construction: Aluminum

Height: 4100mm

WLL: 250kg



Part No: OEM00545

2 Tier Mining Truck Tray Safety Access Platform

MODEL C

- Anti-slip stairway and work area
- Safety handrails
- Lockable swivel wheels

Construction: Aluminum

WLL: 250kg



Part No: OEM00564

MINING TRUCK

Access Platforms

Designs available to suit all Makes & Models



Mining Truck Tray Safety Access Platform MODEL D

- Anti-slip stairway and work area
- Safety handrails
- Forklift pockets

Construction: Aluminum

WLL: 250kg



Part No: OEM00674

Mining Truck Tray Side Mount Tray Safety Access Platform MODEL E

- Anti-slip stairway and work area
- Safety handrails
- Self-closing gates
- Lockable swivel wheels
- Forklift pockets
- Overhang
- Extended handrails

Construction: Aluminum

Height: 2205mm

WLL: 250kg



Part No: OEM01159

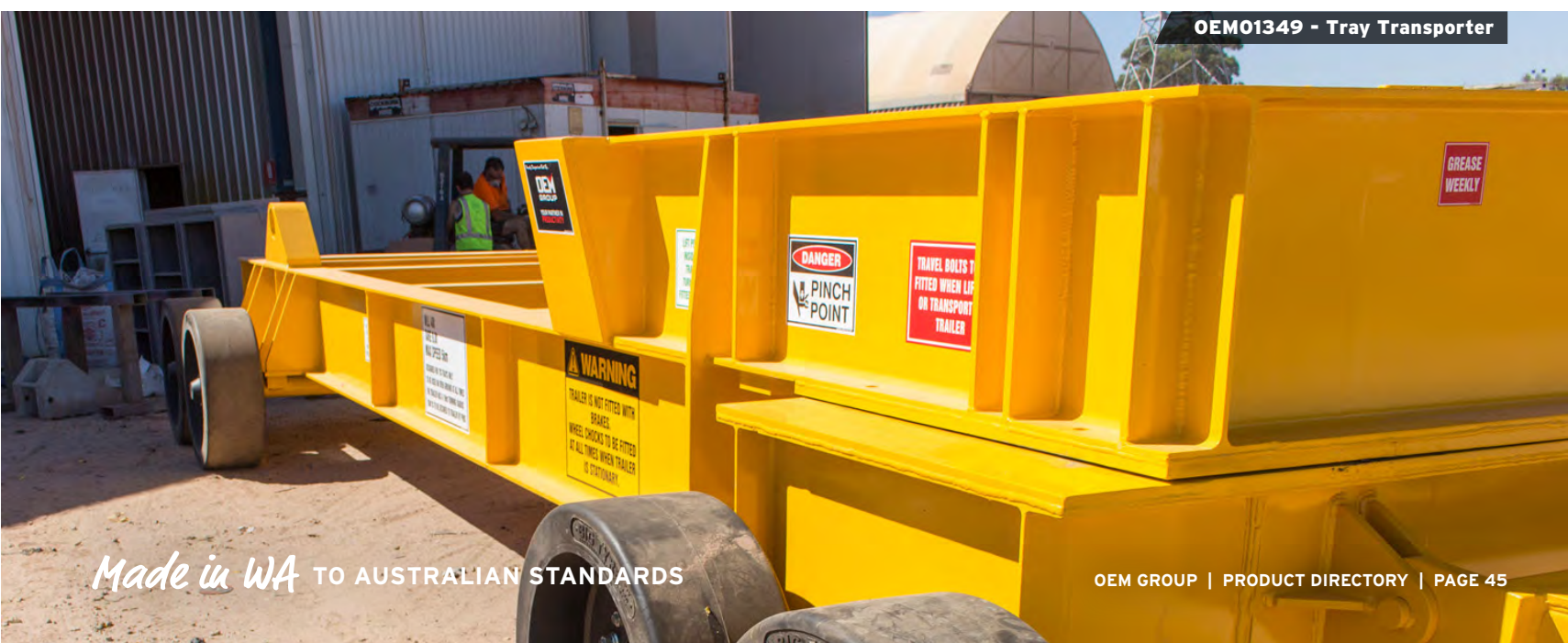

OEM01349 - Tray Transporter

Made in WA TO AUSTRALIAN STANDARDS

MINING TRUCK

Access Platforms

Designs available to suit all Makes & Models



Mining Truck Multi Level Tool Tray Safety Access Platform MODEL F

- Anti-slip stairway and work area
- Safety handrails
- Overhang
- Gate
- Jacking stand
- Counterweight

Construction: Aluminum

WLL: 250kg



Part No: OEM01372

Mining Truck Tray Safety Access Platform MODEL G

- Anti-slip stairway and work area
- Safety handrails
- Forklift pockets
- Gate
- Jacking stand

Construction: Aluminum

WLL: 250kg



Part No: OEM01377

Rock Ejector Safety Access Platform

- Anti-slip stairway and work area
- Safety handrails
- Self-closing gates
- Forklift pockets
- Overhang

Construction: Aluminum

WLL: 250kg



Part No: OEM00289



CUSTOM FABRICATION

Made in WA TO AUSTRALIAN STANDARDS

MINING TRUCK

Access Platforms

Designs available to suit all Makes & Models

Lift Cylinder Side Access Platform MODEL A

- Anti-slip stairway and work area
- Safety handrails
- Lockable swivel wheels

Construction: Aluminum

WLL: 250kg



Part No: OEM00943

Lift Cylinder Centre Access Platform MODEL B

- Anti-slip stairway and work area
- Safety handrails
- Lockable swivel wheels
- Forklift pockets
- Gate
- Boom arm

Construction: Aluminum

WLL: 250kg



Part No: OEM01142

Lift Cylinder Access Platform MODEL C

- Anti-slip stairway and work area
- Safety handrails
- Forklift pockets
- Overhang

Construction: Aluminum

WLL: 250kg



Part No: OEM01075

MINING TRUCK

Access Platforms

Designs available to suit all Makes & Models



Lift Cylinder Access Platform MODEL D

- Anti-slip stairway and work area
- Safety handrails
- Lockable swivel wheels

Construction: Aluminum

Height: 1900mm

WLL: 250kg



Part No: OEM00758

Lift Cylinder Access Platform MODEL E

- Anti-slip stairway and work area
- Lockable swivel wheels

Construction: Aluminum

Height: 4100mm

WLL: 250kg



Part No: OEM01222

Strut Safety Access Platform MODEL A

- Anti-slip stairway and work area
- Safety handrails
- Self-closing gates
- Lockable swivel wheels
- Tool tray

Construction: Aluminum

Height: 2005mm

WLL: 250kg



Part No: OEM01071

MINING TRUCK

Access Platforms

Designs available to suit all Makes & Models

Dual Radiator Safety Access Platform MODEL A

- Anti-slip stairway and work area
- Safety handrails
- Self-closing gates
- Lockable swivel wheels
- Counterweight
- Tool tray

Construction: Aluminum

Height: 1400mm

WLL: 250kg



Part No: OEM00947

Radiator Safety Access Platform MODEL B

- Anti-slip stairway

Construction: Aluminum

Forklift Slots: Nil

WLL: 250kg



Part No: OEM00937

Radiator Safety Access With Work Platform MODEL C

- Anti-slip stairway and work area
- Safety handrails
- Self-closing gates
- Lockable swivel wheels

Construction: Aluminum

Height: 1640mm

WLL: 250kg



Part No: OEM00938

MINING TRUCK

Access Platforms

Designs available to suit all Makes & Models



Can't find what you want?
Contact us at
+61 8 9270 0200 or
contactoem@oemgroup.com.au

Radiator Safety Access Platform MODEL D

- Anti-slip stairway and work area
- Safety handrails
- Forklift pockets
- Gates

Construction: Aluminum

WLL: 250kg



Part No: OEM01011

2 Work Area Radiator Safety Access Platform MODEL E

- Anti-slip stairway and work area
- Safety handrails
- Lockable swivel wheels
- Forklift pockets
- Gates
- Jacking stand

Construction: Aluminum

WLL: 250kg



Part No: OEM01255

OEM00417 & OEM00421 - Engine Bay Safety Access Platforms



Made in WA TO AUSTRALIAN STANDARDS

MINING TRUCK

Access Platforms

Designs available to suit all Makes & Models

Rear Pin Safety Access Platform MODEL A

- Anti-slip stairway and work area
- Safety handrails
- Self-closing gates
- Lockable swivel wheels
- Overhang

Construction: Aluminum

WLL: 250kg



Part No: OEM00944

Rear Pin Safety Access Platform MODEL B

- Anti-slip stairway and work area
- Safety handrails
- Self-closing gates
- Lockable swivel wheels
- Overhang

Construction: Aluminum

WLL: 250kg



Part No: OEM00932

Rear Pin Safety Access Platform MODEL C

- Anti-slip stairway and work area
- Safety handrails
- Overhang

Construction: Aluminum

WLL: 250kg



Part No: OEM01004

MINING TRUCK

Access Platforms

Designs available to suit all Makes & Models



Can't find what you want?
Contact us at
+61 8 9270 0200 or
contactoem@oemgroup.com.au

Rear Pin Safety Access Platform MODEL D

- Anti-slip stairway and work area
- Safety handrails
- Forklift pockets
- Overhang

Construction: Aluminum

WLL: 250kg



Part No: OEM01252

Rear Tray Pin Access Platform

- Anti-slip stairway and work area
- Safety handrails
- Forklift pockets

Construction: Aluminum

WLL: 250kg



Part No: OEM01528

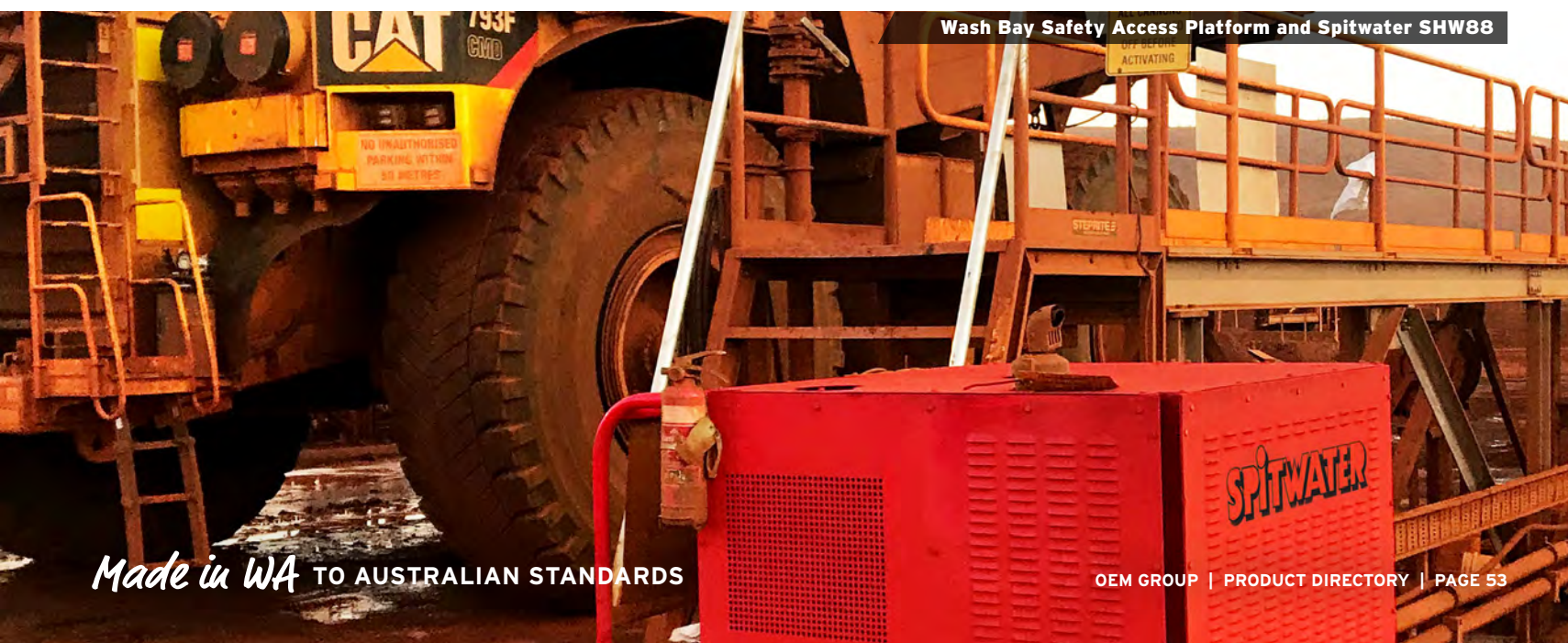

Wash Bay Safety Access Platform and Spitwater SHW88

Made in WA TO AUSTRALIAN STANDARDS

MINING TRUCK

Access Platforms

Designs available to suit all Makes & Models

Strut Safety Access Platform MODEL A

- Anti-slip stairway and work area
- Safety handrails
- Self-closing gates
- Lockable swivel wheels
- Forklift pockets
- Overhang
- Flip-up platform

Construction: Aluminum

Height: 2000mm

WLL: 250kg



Part No: OEM00633

Transmission Safety Access Platform MODEL A

- Anti-slip stairway and work area
- Lockable swivel wheels

Construction: Aluminum

WLL: 250kg



Part No: OEM00933

Transmission Safety Access Platform MODEL B

- Anti-slip stairway and work area
- Handles

Construction: Aluminum

WLL: 250kg



Part No: OEM00802

MINING TRUCK

Access Platforms

Designs available to suit all Makes & Models



Static Transmission Safety Access Platform MODEL B

- Anti-slip stairway and work area
- Lockable swivel wheels
- Jacking stand

Construction: Aluminum

WLL: 250kg

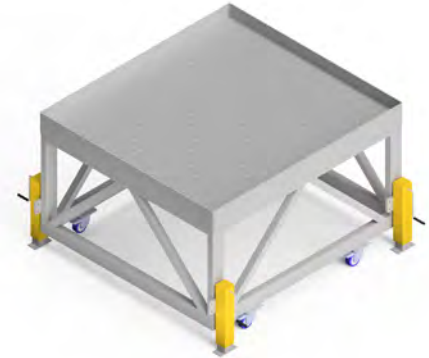

Part No: OEM00851

Left Hand Wheel End Platform MODEL A

- Anti-slip stairway and work area
- Safety handrails
- Forklift pockets

Construction: Aluminum

WLL: 250kg



Part No: OEM00629

Right Hand Wheel End Platform MODEL B

- Anti-slip stairway and work area
- Safety handrails
- Forklift pockets

Construction: Aluminum

WLL: 250kg



Part No: OEM00635

MINING TRUCK

Access Platforms

Designs available to suit all Makes & Models



Wheel Nut Safety Access Platform MODEL A

- Anti-slip stairway and work area
- Safety handrails
- Lockable swivel wheels

Construction: Aluminum

WLL: 250kg



Part No: OEM01134

Wheel Nut Safety Access Platform MODEL B

- Anti-slip stairway and work area
- Safety handrails
- Forklift pockets
- Gantry to hold RAD gun

Construction: Aluminum

WLL: 250kg



Part No: OEM00805

Wheel Nut Safety Access Platform MODEL C

- Anti-slip stairway and work area
- Safety handrails
- Forklift pockets
- Gantry to hold RAD gun

Construction: Aluminum

WLL: 250kg



Part No: OEM01550



HELPING YOU REACH PEAK EFFICIENCY

Made in WA TO AUSTRALIAN STANDARDS

EXCAVATOR

Access Platforms

Designs available to suit all Makes & Models

Multi Work Deck Dipper Maintenance Platform

- Anti-slip stairway and work area
- Safety handrails
- Lockable swivel wheels
- Forklift pockets

Construction: Steel

WLL: 2T



Part No: OEM00527

Two Level Dipper Maintenance Platform

- Anti-slip stairway and work area
- Safety handrails

Construction: Steel

WLL: 2T



Part No: OEM00531

Boom Stand

- Anchor points

Construction: Steel

WLL: 100T

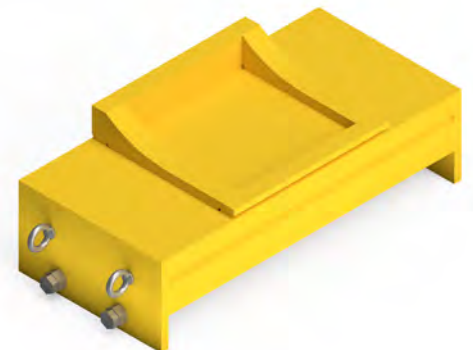

Part No: OEM01224

EXCAVATOR

Access Platforms

Designs available to suit all Makes & Models



Hydraulic Adjustable Platform

- Anti-slip stairway and work area
- Safety handrails
- Lockable swivel wheels
- Forklift pockets
- Manual over hydraulic

Construction: Steel

WLL: Various



Part No: OEM00419

Bucket Maintenance Platform

- Anti-slip stairway and work area
- Safety handrails
- Self-closing gates
- Lockable swivel wheels
- Forklift pockets
- Removable handrail

Construction: Aluminum

Height: 1900mm

WLL: 250kg



Part No: OEM01275

OEM Group are a WA Based company operating for over 40 years, we design and manufacture a huge range of custom built Safety Access Platforms, to suit all industries. Our platforms are built specifically to optimise your productivity and safety. You bring us your problem and OEM will find you the perfect solution.

LOADER

Stands, Accessories & Tools

Designs available to suit all Makes & Models

Axle Stand MODEL A

- Forklift pockets

Construction: Steel

WLL: 20T



Part No: OEM00287

Axle Stand MODEL B

- Forklift pockets

Construction: Steel

WLL: 20T



Part No: OEM00346

Artic Squat Stands MODEL A

Construction: Steel

Height: 1000mm

WLL: 80T



Part No: OEM00574

Artic Squat Stands MODEL B

Construction: Steel

Height: 945mm

WLL: 80T



Part No: OEM01319

Bucket Support Stand

- Forklift pockets

Construction: Steel

WLL: 80T



Part No: OEM00296

Diff Skates

- Anchor points

Construction: Steel

WLL: 16T

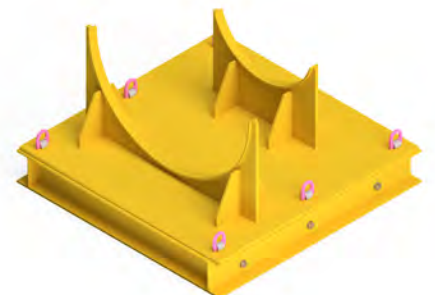

Part No: OEM00619

LOADER

Stands, Accessories & Tools

Designs available to suit all Makes & Models



Loader Arm Stand MODEL A

- Forklift pockets

Construction: Steel

Height: 3000mm

WLL: 80T



Part No: OEM00699

Loader Arm Stand MODEL B

- Forklift pockets

Construction: Steel

Height: 3600mm

WLL: 80T



Part No: OEM00750

Loader Arm Stand MODEL C

- Forklift pockets

Construction: Steel

Height: 3900mm

WLL: 80T



Part No: OEM00751

Loader Arm Stand MODEL D

- Forklift pockets

Construction: Steel

Height: 2300mm

WLL: 80T



Part No: OEM01024



Made in WA TO AUSTRALIAN STANDARDS

LOADER

Stands, Accessories & Tools

Designs available to suit all Makes & Models

Loader Arm Stand MODEL E

- Forklift pockets

Construction: Steel

Height: 5000mm

WLL: 80T



Part No: OEM00308

Loader Arm Stand MODEL F

- Forklift pockets

Construction: Steel

Height: 4500mm

WLL: 80T



Part No: OEM00231

Loader Arm Stand MODEL G

- Forklift pockets

Construction: Steel

Height: 2800mm

WLL: 80T



Part No: OEM00338

Loader Arm Stand MODEL H

- Forklift pockets

Construction: Steel

Height: 3500mm

WLL: 80T



Part No: OEM00701

Loader Arm Stand MODEL I

Construction: Steel

Height: 5000mm

WLL: 80T



Part No: OEM00732

Loader Arm Stand MODEL J

Construction: Steel

WLL: 80T



Part No: OEM00960

LOADER

Stands, Accessories & Tools

Designs available to suit all Makes & Models



Loader Arm Stand MODEL K

- Forklift pockets

Construction: Steel

Height: 3850mm

WLL: 80T



Part No: OEM00844

Radiator Stand

- Forklift pockets

Construction: Steel

Height: 1910mm

WLL: 1T



Part No: OEM00423

Loader Assembly Stands

- Forklift pockets

Construction: Steel

Heights: 835mm, 1130mm, 1400mm

WLL: 200T



Part No: OEM00762



OEM00844 - Loader Arm Stand

Made in WA TO AUSTRALIAN STANDARDS



PROUDLY

WEST AUSTRALIAN

OWNED & OPERATED

LOADER

Access Platforms

Designs available to suit all Makes & Models



Artic Safety Access Platform MODEL A

- Anti-slip stairway and work area
- Safety handrails
- Lockable swivel wheels
- Overhang

Construction: Aluminum

WLL: 250kg



Part No: OEM00623

Artic Safety Access Platform MODEL B

- Anti-slip stairway and work area
- Safety handrails
- Lockable swivel wheels
- Forklift pockets
- Overhang
- Gate
- Boom arm

Construction: Aluminum

WLL: 250kg



Part No: OEM00305

Lower Right Hand Artic Safety Access Platform MODEL C

- Anti-slip stairway and work area
- Safety handrails
- Self-closing gates
- Lockable swivel wheels
- Forklift pockets
- Overhang
- Jacking stand

Construction: Aluminum

WLL: 250kg



Part No: OEM00482

LOADER

Access Platforms

Designs available to suit all Makes & Models

Lower Left Hand Artic Safety Access Platform MODEL D

- Anti-slip stairway and work area
- Safety handrails
- Self-closing gates
- Lockable swivel wheels
- Forklift pockets
- Overhang

Construction: Aluminum

WLL: 250kg



Part No: OEM00521

Artic Safety Access Platform MODEL E

- Anti-slip stairway and work area
- Safety handrails
- Lockable swivel wheels
- Overhang

Construction: Aluminum

WLL: 250kg



Part No: OEM00575

Artic Safety Access Platform MODEL F

- Anti-slip stairway and work area
- Safety handrails
- Lockable swivel wheels
- Gate

Construction: Aluminum

WLL: 250kg



Part No: OEM00934

LOADER

Access Platforms

Designs available to suit all Makes & Models



Assembly Safety Access Platform

- Anti-slip stairway and work area
- Safety handrails
- Self-closing gates
- Lockable swivel wheels
- Overhang
- Gate

Construction: Aluminum

WLL: 250kg



Part No: OEM00936

Bucket Maintenance Platform

- Anti-slip stairway and work area
- Safety handrails
- Self-closing gates
- Lockable swivel wheels
- Forklift pockets
- Removable handrail

Construction: Aluminum

Height: 1900mm

WLL: 250kg



Part No: OEM01275

Tilt Cylinder Safety Access Platform

MODEL A

- Anti-slip work area
- Safety handrails

Construction: Steel

WLL: 250kg

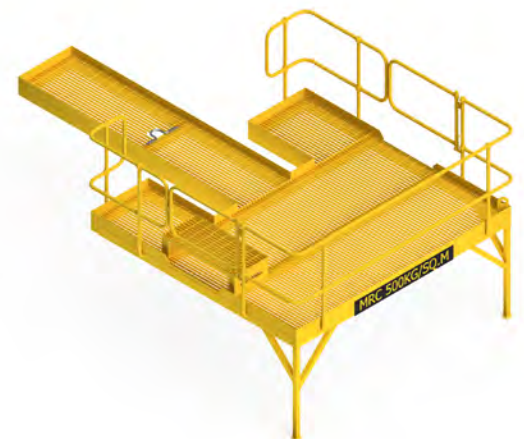

Part No: OEM00720

LOADER

Access Platforms

Designs available to suit all Makes & Models

Lift Cylinder Safety Access Platform MODEL A

- Anti-slip work area
- Safety handrails
- Gate

Construction: Aluminum

Height: 3900mm

WLL: 250kg



Part No: OEM00719

Lower Tilt Cylinder Safety Access Platform MODEL B

- Anti-slip stairway and work area
- Safety handrails
- Self-closing gates
- Forklift pockets

Construction: Aluminum

Height: 674mm

WLL: 250kg



Part No: OEM00757

Tilt Cylinder Safety Access Platform with Stairs MODEL C

- Anti-slip stairway and work area
- Safety handrails
- Lockable swivel wheels
- Overhang
- Gate
- Jacking stand

Construction: Aluminum

WLL: 250kg



Part No: OEM00489

LOADER

Access Platforms

Designs available to suit all Makes & Models



Tilt Cylinder Safety Access Platform MODEL D

- Anti-slip work area
- Safety handrails
- Gates

Construction: Aluminum

WLL: 250kg

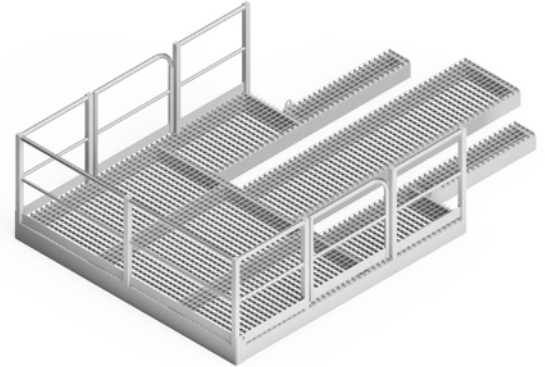

Part No: OEM00576

Lift Cylinder Safety Access Platform MODEL E

- Anti-slip stairway and work area
- Safety handrails
- Self-closing gates
- Lockable swivel wheels
- Overhang
- Gate

Construction: Aluminum

WLL: 250kg



Part No: OEM00935

Tilt Cylinder Safety Access Platform MODEL F

- Anti-slip stairway and work area
- Safety handrails
- Self-closing gates
- Lockable swivel wheels

Construction: Aluminum

WLL: 250kg



Part No: OEM00945

LOADER

Access Platforms

Designs available to suit all Makes & Models



Lift Cylinder Pin Safety Access Platform

- Anti-slip stairway and work area
- Safety handrails
- Lockable swivel wheels
- Forklift pockets
- Overhang
- Jacking stand

Construction: Aluminum

WLL: 250kg



Part No: OEM01419

Rear Safety Access Platform

- Anti-slip stairway and work area
- Safety handrails
- Self-closing gates
- Lockable swivel wheels
- Forklift pockets

Construction: Aluminum

Height: 2120mm

WLL: 250kg



Part No: OEM00644



OEM00750 - Boom Arm Stand



MAXIMISING

ON-SITE PERFORMANCE

Made in WA TO AUSTRALIAN STANDARDS

DOZER

Stands, Accessories & Tools

Designs available to suit all Makes & Models

Draft Arm Stand MODEL D

Construction: Steel
Height: 600mm
WLL: 16T



Part No: OEM00939

Draft Arm Stand MODEL E

Construction: Steel
Height: 1200mm
WLL: 16T



Part No: OEM01023



DOZER

Access Platforms

Designs available to suit all Makes & Models

Engine Bay Safety Access Platform MODEL A

- Anti-slip stairway and work area
- Safety handrails
- Self-closing gates
- Lockable swivel wheels
- Overhang

Construction: Aluminum

Height: 1980mm

WLL: 250kg



Part No: OEM00711

Engine Bay Safety Access Platform MODEL B

- Anti-slip stairway and work area
- Safety handrails
- Self-closing gates
- Lockable swivel wheels
- Overhang

Construction: Aluminum

Height: 1760mm

WLL: 250kg



Part No: OEM00770

Engine Bay Safety Access Platform MODEL C

- Anti-slip stairway and work area
- Safety handrails
- Self-closing gates
- Lockable swivel wheels
- Overhang
- Tool tray
- Boom arm

Construction: Aluminum

WLL: 250kg



Part No: OEM00290



DOZER

Access Platforms

Designs available to suit all Makes & Models

Engine Bay Safety Access Platform MODEL D

- Anti-slip stairway and work area
- Safety handrails
- Self-closing gates
- Lockable swivel wheels
- Forklift pockets
- Overhang

Construction: Aluminum

WLL: 250kg



Part No: OEM00460

Engine Bay Safety Access Platform MODEL E

- Anti-slip stairway and work area
- Safety handrails
- Lockable swivel wheels
- Forklift pockets
- Overhang
- Gates

Construction: Aluminum

WLL: 250kg



Part No: OEM00500

Engine Bay Safety Access Platform MODEL F

- Anti-slip stairway and work area
- Safety handrails
- Self-closing gates
- Lockable swivel wheels
- Overhang

Construction: Aluminum

Height: 1760mm

WLL: 250kg



Part No: OEM00710

DOZER

Access Platforms

Designs available to suit all Makes & Models



Engine Bay Safety Access Platform MODEL G

- Anti-slip stairway and work area
- Safety handrails
- Self-closing gates
- Lockable swivel wheels
- Forklift pockets
- Overhang
- Counterweight

Construction: Aluminum

Height: 1760mm

WLL: 250kg



Part No: OEM00768

Engine Bay Left Hand Safety Access Platform MODEL H

- Anti-slip stairway and work area
- Safety handrails
- Self-closing gates
- Lockable swivel wheels
- Sliding platform

Construction: Aluminum

Height: 1820mm

WLL: 250kg



Part No: OEM00417

Engine Bay Right Hand Safety Access Platform MODEL I

- Anti-slip stairway and work area
- Safety handrails
- Self-closing gates
- Lockable swivel wheels
- Sliding platform

Construction: Aluminum

Height: 1820mm

WLL: 250kg

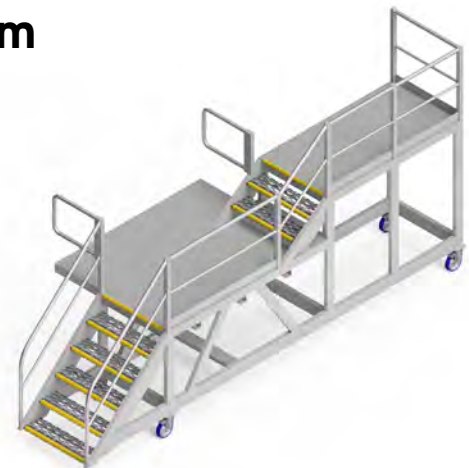

Part No: OEM00421

DOZER

Access Platforms

Designs available to suit all Makes & Models



Front Safety Access Platform MODEL A

- Anti-slip stairway and work area
- Safety handrails
- Self-closing gates
- Lockable swivel wheels
- Forklift pockets

Construction: Aluminum

WLL: 250kg



Part No: OEM00645

Front Safety Access Platform MODEL B

- Anti-slip stairway and work area
- Safety handrails
- Self-closing gates
- Lockable swivel wheels
- Forklift pockets

Construction: Aluminum

WLL: 250kg



Part No: OEM00649

Front Safety Access Platform MODEL C

- Anti-slip stairway and work area
- Safety handrails
- Self-closing gates
- Lockable swivel wheels
- Forklift pockets

Construction: Aluminum

WLL: 250kg



Part No: OEM00652



WE CAN DESIGN TO SUIT
ALL MAKES AND MODELS

Made in WA TO AUSTRALIAN STANDARDS

DOZER

Access Platforms

Designs available to suit all Makes & Models



Extended Lift Cylinder Safety Access Platform MODEL A

- Anti-slip stairway and work area
- Safety handrails
- Lockable swivel wheels
- Forklift pockets
- Overhang
- Counterweight

Construction: Aluminum

WLL: 250kg



Part No: OEM01077

Right Hand Lift Cylinder Safety Access Platform MODEL B

- Anti-slip stairway and work area
- Safety handrails
- Lockable swivel wheels
- Overhang

Construction: Aluminum

WLL: 250kg



Part No: OEM00675

Centre Lift Cylinder Safety Access Platform MODEL C

- Anti-slip stairway and work area
- Safety handrails
- Lockable swivel wheels
- Forklift pockets
- Overhang
- Counterweight

Construction: Aluminum

WLL: 250kg



Part No: OEM00800



INNOVATIVE DESIGNS

Made in WA TO AUSTRALIAN STANDARDS

RECOVERY TRAILER

Introducing the latest innovation in heavy-vehicle recovery!

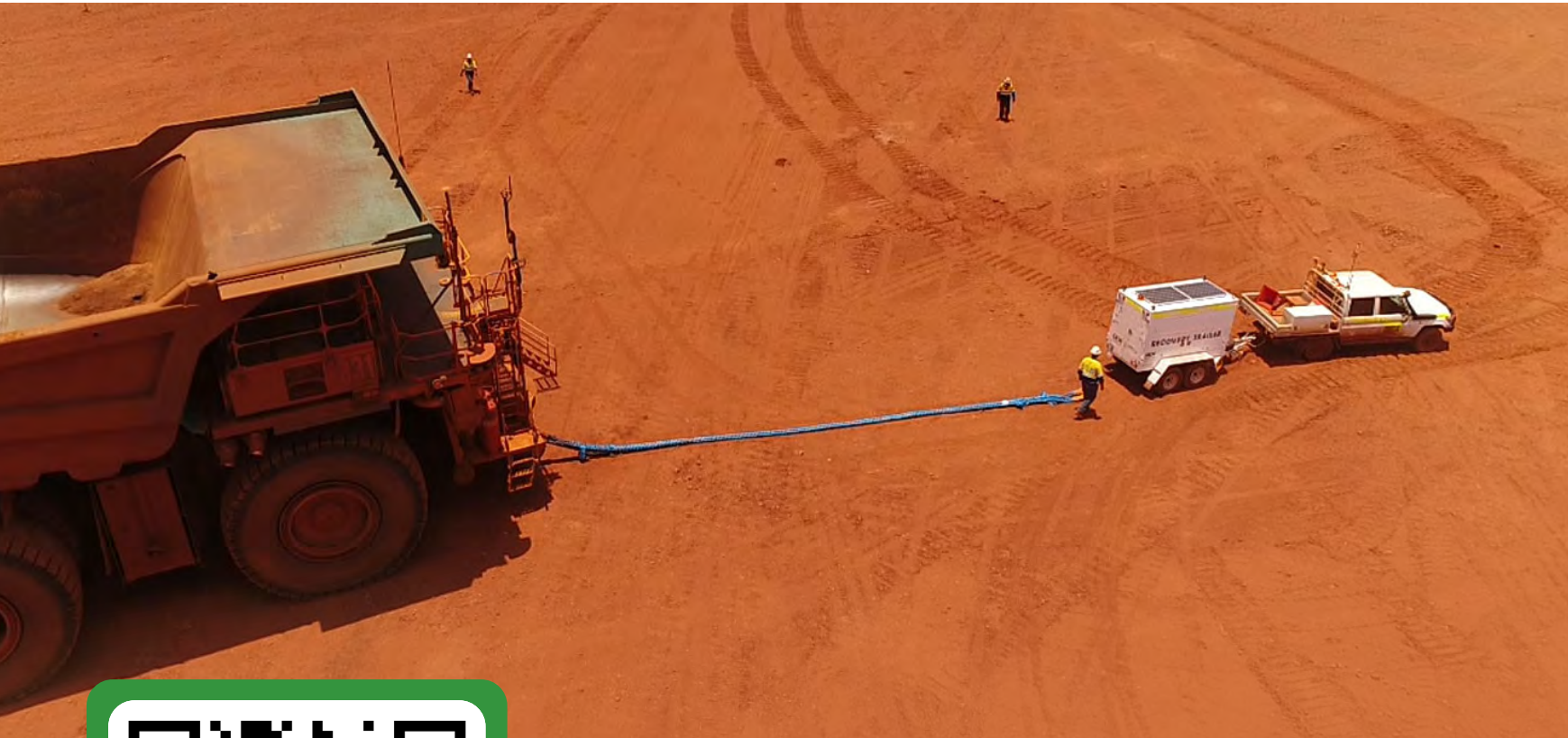

SCAN THE
QR CODE TO
WATCH A
VIDEO OF OUR
RECOVERY
TRAILER
IN ACTION

We have revolutionised heavy-vehicle recovery with our latest innovation, the OEM Group Heavy Equipment Recovery Trailer.

The self-contained mobile Recovery Trailer offers a safe and convenient solution for heavy vehicle and equipment recovery.

Custom designed and fabricated at OEM Group's workshop in Western Australia the all-in-one management system is a proven performer in the assisting of mobile heavy-vehicle recovery.

The mobile, heavy-duty unit is built to perfectly suit towing heavy-duty assets and designed to mine specifications for a safe, and speedy recovery of heavy vehicles in any situation.

The trailer is self-contained to store and protect key equipment from the elements and to avoid any potential injury hazards, and features a powerful hydraulic winch, integrated rope, hitch and more.

Flexible Solutions

There are two available designs for the OEM Group Heavy Equipment Recovery Trailer.

The standard design is fitted with a single hydraulic winch while the upgraded design is fitted with two hydraulic winces or can be fitted with a Hiab to eliminate all manual lifting, so the potential for operator injury is significantly reduced.

The powerful, fully integrated, hydraulic winch safely and reliably unspools a massive tow rope for attaching to the equipment. The winch is run by a diesel motor and easily respools the rope for next use. Each trailer is fitted with powerful, battery-operated, work lights for 24/7 operation. Solar Panels on the canopy roof then charge these batteries during the day, saving power.

Each feature on the Recovery Trailer has been designed for safe and effective vehicle recovery, saving manpower and time on-site.

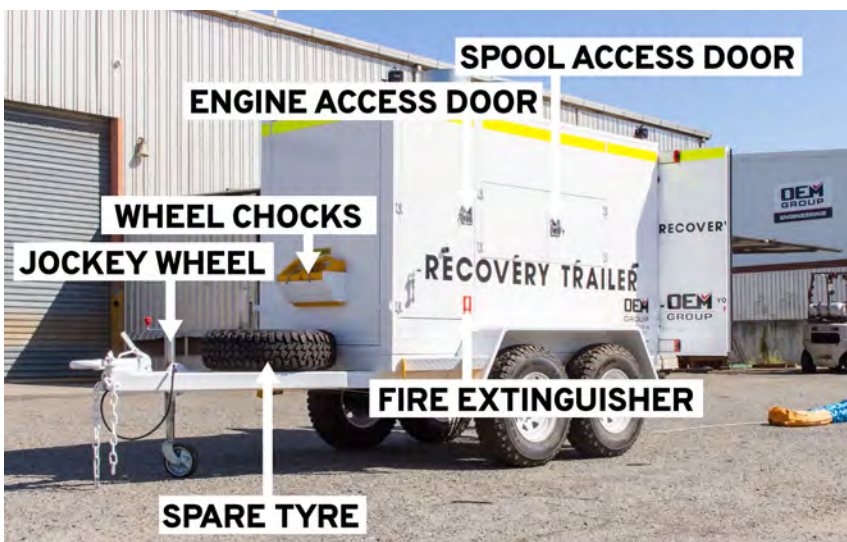
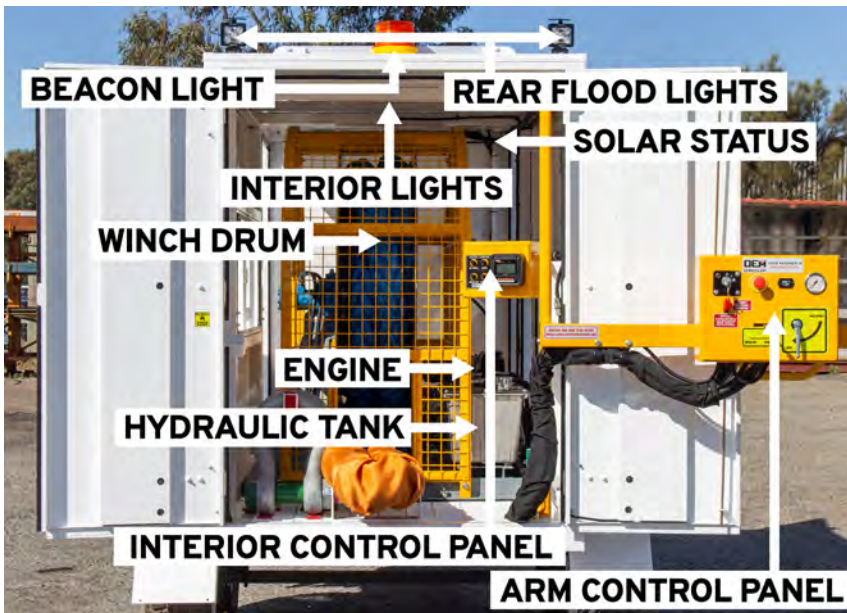

Key Features

- Heavy Duty custom design and fabricated by OEM Group
- All-in-one management system for heavy-duty towing assets
- Self-contained unit with an integrated rope, hitch, hydraulic winch and more
- Protects tow ropes from the outside weather conditions
- Self sufficient with solar panels, batteries and work lights for night recovery
- Designed to meet all mine site specifications
- Proven performer

03

WORKSHOP SOLUTIONS

Storage	84 - 85
Stands	86 - 95
Racking	96 - 97
Benches	98 - 99
Shelving	100 - 101
Wheel Chocks - <i>Westchock</i>	102 - 103



STORAGE

Chain Storage

Crane Chain Storage

Construction: Steel
WLL: Various

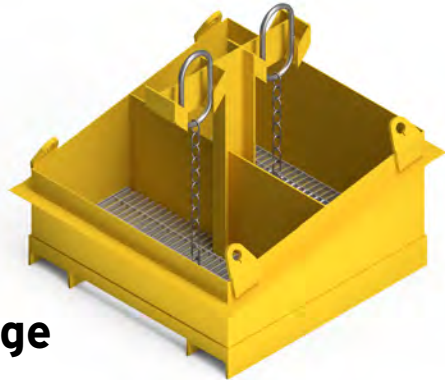

Part No: OEM00716a

Lockable Crane Chain Storage

Construction: Steel
WLL: 2.6T



Part No: OEM00716c

Heavy Duty Chain Rack

Construction: Steel
WLL: Various

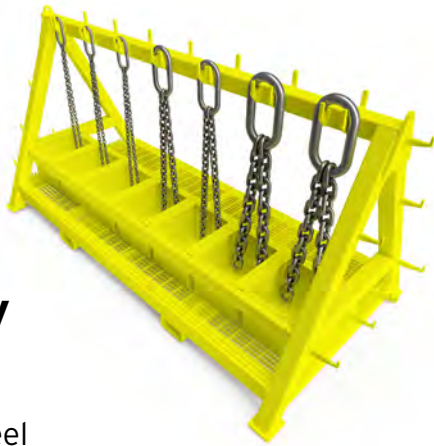

Part No: OEM01545

Heavy Duty Peg Board

Construction: Steel & Aluminum
WLL: Various



Part No: OEM01544



OEM00578 - Roller Cabinet

STORAGE

Mobile Storage



Mobile Drum Trolley

- Anti-slip Deck
- Lockable Swivel Wheels

Construction: Steel/Aluminum

WLL: Various

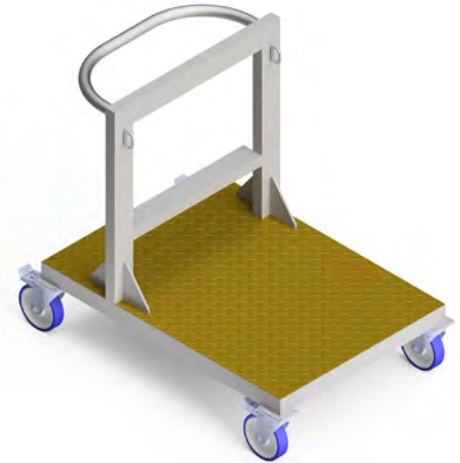

Part No: OEM00775

Mobile Oil Drip Tray

- Portable Oil Drip Tray
- Drain Plugs
- Lockable Swivel Wheels

Construction: Aluminum

WLL: Various

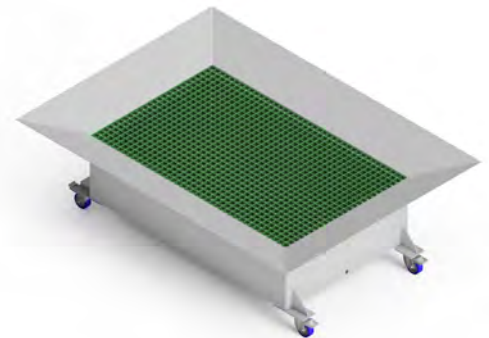

Part No: OEM00577

Roller Cabinet

- Lockable
- Heavy Duty Swivel Wheels

Construction: Steel

WLL: Various



Part No: OEM00578

STANDS

Support Stands



Can't find what you want?
Contact us at
+61 8 9270 0200 or
contactoem@oemgroup.com.au

20T Mobile Stand

- Ø80mm Wheels
- Construction:** Steel
WLL: 20T



Part No: OEM00395

50T Adjustable Stand

- Construction:** Steel
WLL: 50T



Part No: OEM00767

25T Stand 550mm

- Construction:** Steel
WLL: 25T



Part No: OEM01346

50T Jacking Stand

- Hydraulic Adjustment
- Construction:** Steel
Height: 613mm - 1008mm
WLL: 50T



Part No: OEM00818

OEM00942 - Cradle Cap Suit 55T and OEM00941 - 55T Jacking Stand





OEM GROUP JACKRITE

WLL 100T
WORKING LOAD LIMIT 100T

⚠ WARNING: USE ONLY ON HARD LEVEL SURFACES SUCH AS CONCRETE, CAPABLE OF SUSTAINING LOAD.

THIS STAND HAS BEEN SPECIFICALLY DESIGNED FOR THE CAT 793F, AND SHOULD ONLY BE USED IN THIS APPLICATION

LOAD SHOULD BE EVENLY DISTRIBUTED CENTRALLY OVER THE TOP PLATE(S)

SCENE 150005 0204 0110

WORKSHOP SOLUTIONS

WE SLASH
DOWNTIME COSTS

STANDS

Support Stands

Pickup Points: Forklift & Trolley

Construction: Steel

WLL: 55T



**55T Jacking
Stand 280mm**

Part No: OEM00265



**55T Jacking
Stand 350mm**

Part No: OEM00264

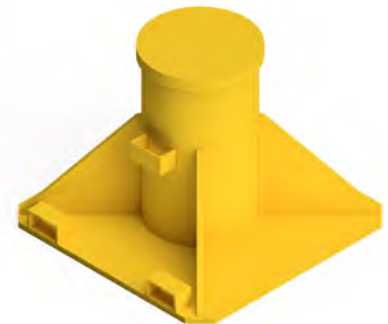

**55T Jacking
Stand 500mm**

Part No: OEM00263



**55T Jacking
Stand 600mm**

Part No: OEM00262

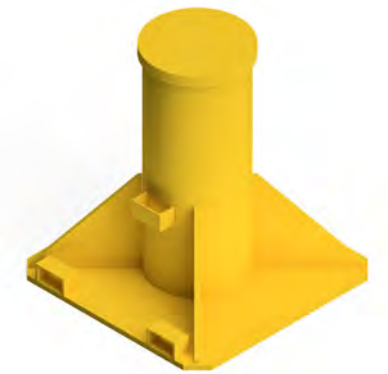

**55T Jacking
Stand 700mm**

Part No: OEM00261

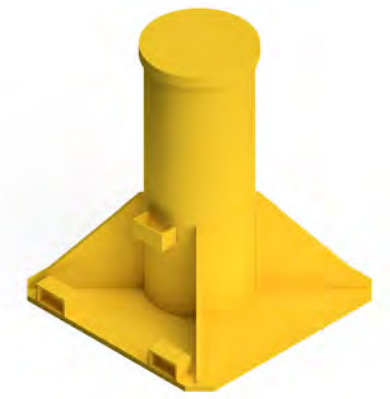

**55T Jacking
Stand 750mm**

Part No: OEM00260

STANDS

Support Stands

Pickup Points: Forklift & Trolley

Construction: Steel

WLL: 55T

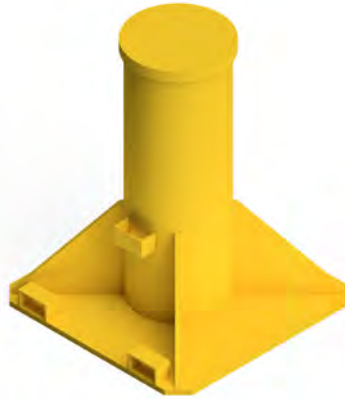

55T Jacking Stand 800mm

Part No: OEM00286

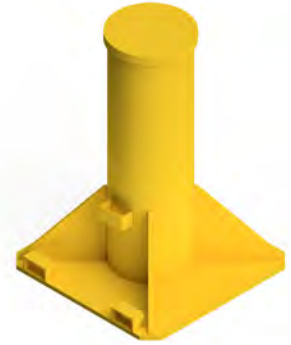

55T Jacking Stand 900mm

Part No: OEM00259

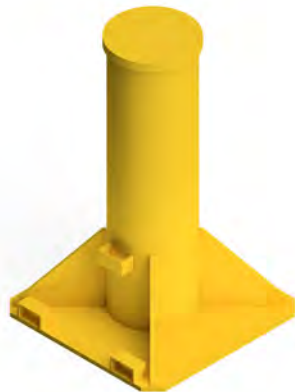

55T Jacking Stand 1000mm

Part No: OEM00258



55T Jacking Stand 1300mm

Part No: OEM00241

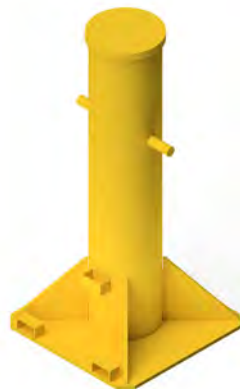

55T Jacking Stand 1320mm

Part No: OEM00941



55T Jacking Stand 1340mm

Part No: OEM00697

STANDS

Support Stands

Pickup Points: Forklift & Trolley

Construction: Steel

WLL: 55T

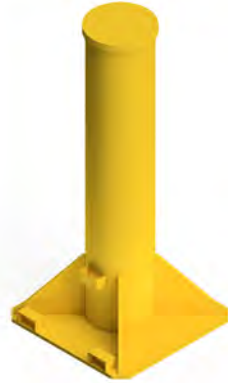

55T Jacking Stand 1400mm

Part No: OEM00240

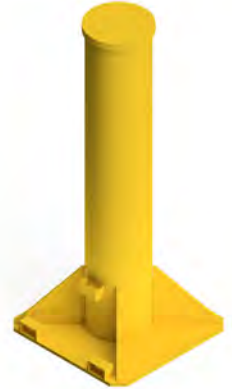

55T Jacking Stand 1500mm

Part No: OEM00257



55T Jacking Stand 1580mm

Part No: OEM00940

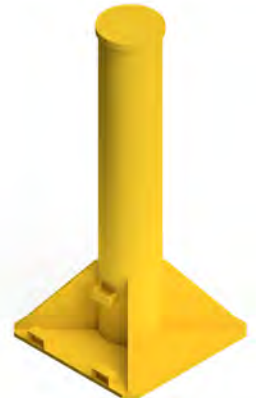

55T Jacking Stand 1600mm

Part No: OEM00239



55T Jacking Stand 1700mm

Part No: OEM00266



55T Jacking Stand 1800mm

Part No: OEM01334



WLL 150T
WORKING LOAD LIMIT 150T
WARNING: USE ONLY ON
HARD LEVEL SURFACE
(E.G. CONCRETE CAPABLE
OF SUSTAINING LOAD)
LOADS SHOULD BE EVENLY
DISTRIBUTED CENTRALLY
OVER THE TOP PLATES
OEM
GROUP
YOUR PARTNER IN
www.oemgroup.com.au
(08) 9270 0200

OPERATING INSTRUCTIONS
1. Before placing loads, ensure that the machine is on a level and stable surface and a solid level surface (e.g. concrete capable of sustaining load).
2. If any of the stands feet will have any ground clearance or distributed ground clearance, ensure the pressure is fully applied and the machine is level. All 4 feet to be in contact with the ground.
3. Maximum loads under machine to be applied evenly.
4. Do not release the air from the air lines while the machine is on the stand. The stands are designed so that when the height of the machine rises into the air, the air pressure and the base of the stand will contact the ground.

WLL 150T
WORKING LOAD LIMIT 150T
WARNING: USE ONLY ON
HARD LEVEL SURFACE
(E.G. CONCRETE CAPABLE
OF SUSTAINING LOAD)
OEM
GROUP
YOUR PARTNER IN
www.oemgroup.com.au
(08) 9270 0200

Heavy Duty Custom Design

STANDS

Support Stands

Pickup Points: Forklift & Trolley

Construction: Steel

WLL: 55T



**55T Jacking
Stand 2000mm**

Part No: OEM00267



**55T Jacking
Stand 2100mm**

Part No: OEM00268



STANDS

Support Stands



100T Adjustable Stand

- Hydraulic Adjustment
- Swivel Wheels
- Airbags

Construction: Steel

WLL: 100T



Part No: OEM01213

100T Stillage Stand 550mm

Pickup Points: Yes

Construction: Steel

WLL: 100T

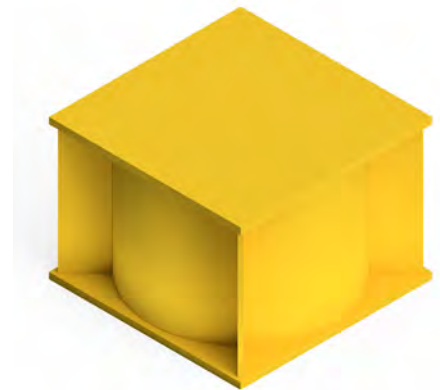

Part No: OEM00288

100T Stillage Stand 1000mm

Pickup Points: Yes

Construction: Steel

WLL: 100T



Part No: OEM00502

STANDS

Stand Trolleys



55T Stand Trolley

- Heavy Duty Wheels

Construction: Steel

WLL: Various



Part No: OEM00840

100T Stand Trolley

- Heavy Duty Wheels

Construction: Steel

WLL: Various



Part No: OEM00896

Inspection Stands

Tyre Inspection Stand

- For heavy vehicle servicing

Construction: Steel

WLL: Various



Part No: OEM00344



RACKING

Steel Racking

Horizontal Steel Rack

- Forklift pockets

Construction: Steel

WLL: Various



Part No: OEM00282

Horizontal Steel Plate Rack

- Forklift pockets

Construction: Steel

WLL: Various



Part No: OEM00529

Vertical Plate Rack

- Forklift pockets

Construction: Steel

WLL: Various

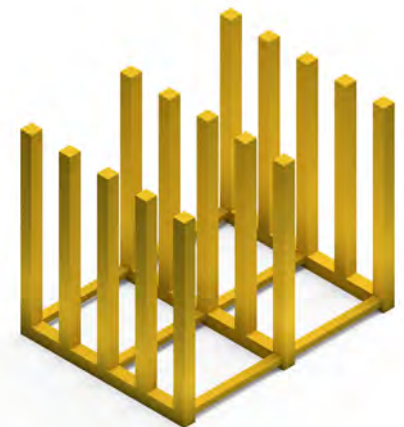

Part No: OEM00741

RACKING

Steel Racking



Horizontal Steel Rack

Construction: Steel
WLL: Various

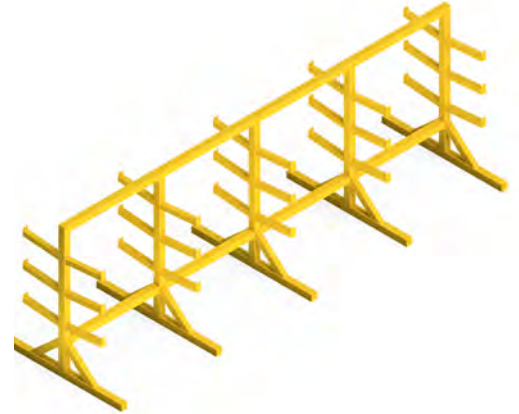

Part No: OEM00742

Horizontal Plate Rack

- Forklift pockets

Construction: Steel
WLL: Various



Part No: OEM00747



BENCHES

Work Benches

Work Bench

Construction: Steel & Aluminum

Height: 950mm

WLL: 1.2T



Part No: OEM00658

Heavy Duty Mobile Work Bench

- On wheels

Construction: Steel

Length: 1700mm

WLL: 1T



Part No: OEM01560

Heavy Duty Work Bench

- Optional extra: drip tray on the outside of the bench

Construction: Steel & Aluminum

WLL: 2T



Part No: OEM01548

BENCHES

Trestles



750kg Trestle

- Lightweight

Construction: Aluminum

Height: 795mm

WLL: 750kg



Part No: OEM00581

1T Trestle

- Lightweight

Construction: Aluminum

Height: 1050mm

WLL: 1T



Part No: OEM00582

1T Trestle

Construction: Steel

WLL: 1T



Part No: OEM01112

2.5T Trestle

- Lightweight

Construction: Aluminum

Height: 830mm

WLL: 2.5T



Part No: OEM00595

2.5T Trestle

- Lightweight

Construction: Aluminum

Height: 840mm

WLL: 2.5T



Part No: OEM00583

SHELVING

Shelving Units

Shelving Unit

Construction: Steel
WLL: Various



Part No: OEM00609

Shelving Unit

Construction: Steel
WLL: Various



Part No: OEM00610

Mobile Shelving Unit

- Lockable Swivel Wheels

Construction: Aluminum
Height: 1450mm
WLL: Various



Part No: OEM00865

Mobile Shelving Unit

- Lockable Swivel Wheels

Construction: Aluminum
Height: 1450mm
WLL: Various



Part No: OEM00900

OEM01453 - Maintenance Shelving



Made in WA TO AUSTRALIAN STANDARDS

OEM GROUP
YOUR PARTNER IN
PRODUCTIVITY

OEM GROUP
YOUR PARTNER IN
PRODUCTIVITY

LEVEL 4 WLL 40kg

LEVEL 4 WLL 40kg

LEVEL 3 WLL 80kg

LEVEL 3 WLL 80kg

LEVEL 2 WLL 160kg

LEVEL 2 WLL 160kg

LEVEL 1 WLL 240kg

SPECIALISTS IN CUSTOM DESIGN & FABRICATION

Made in WA TO AUSTRALIAN STANDARDS

WHEEL CHOCKS - WESTCHOCK

Wheelchocks

Small

- Skid resistant rubber feet
- Foam filled under pressure

Rated to: 5T
Length: 300mm
Width: 240mm
Height: 165mm
Weight: 1.5Kg



Part No: WC1055

Medium

- Skid resistant rubber feet
- Foam filled under pressure

Rated to: 40T
Length: 560mm
Width: 330mm
Height: 280mm
Weight: 8Kg



Part No: WC1075

Large

- Skid resistant rubber feet
- Foam filled under pressure

Rated to: 150T
Length: 580mm
Width: 400mm
Height: 270mm
Weight: 9.5Kg



Part No: WC1105

Extra Large

- Skid resistant rubber feet
- Foam filled under pressure

Rated to: Over 150T
Length: 650mm
Width: 440mm
Height: 390mm
Weight: 12.5Kg



Part No: WC1155



WHEEL CHOCKS - WESTCHOCK

Wheelchock Brackets



Aluminum Bracket

- Stainless steel cable with locking clip
- Pre drilled mounting holes



Suits: WC1055

Part No: WC1055 ALI BRACKET

Zinc Bracket

- Stainless steel cable with locking clip
- Pre drilled mounting holes

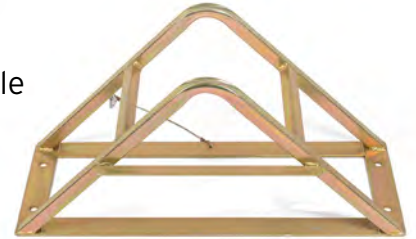

Suits: WC1075

Part No: WC1075 ZINC BRACKET

Zinc Bracket

- Stainless steel cable with locking clip
- Pre drilled mounting holes



Suits: WC1105

Part No: WC1105 ZINC BRACKET

Zinc Bracket

- Stainless steel cable with locking clip
- Pre drilled mounting holes

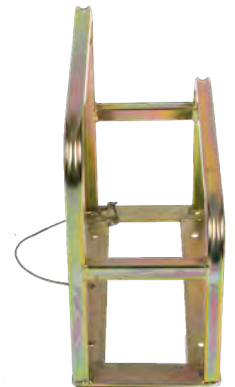

Suits: WC1155

Part No: WC1155 ZINC BRACKET

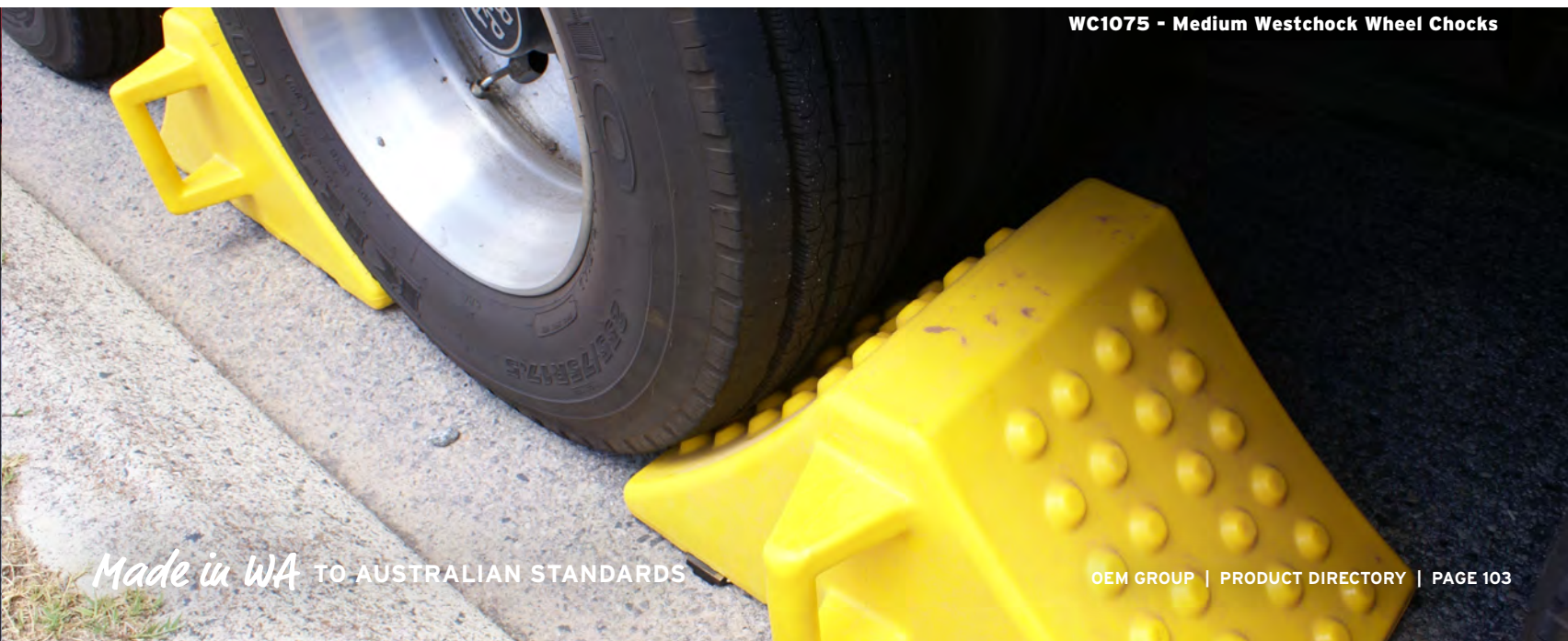

WC1075 - Medium Westchock Wheel Chocks

04

SAFETY ACCESS SOLUTIONS

STEPRITE®	106 - 109
Aviation	110 - 117
Locomotive	118 - 119
Crane	120 - 121
Oil & Gas	122 - 125
Transport	126
Wash Down Bay Platforms	127



STEPRITE® *Work Platform Ladders*

Introducing STEPRITE® Work Platform Ladders now providing safe and reliable access solutions for working at heights. STEPRITE® design and manufacture a range of quality engineered Work Platform Ladders that comply with all your occupational health and safety requirements.

STEPRITE® Work Platform Ladders are constructed from strong, lightweight structural grade aluminium. This results in a quality product requiring minimal maintenance.

All our STEPRITE® Work Platform Ladders have been designed and independently tested and exceed all relevant Australian Standards.

STEPRITE® Work Platform Ladders can be used for working at heights across a wide range of industries such as Mining Maintenance, Aviation, Construction, Transport, Agricultural, Mechanical and Manufacturing workshops.



SWP2000 (Standard)



SMP1500 (Minespec)

Full Range Of Ladders

STEPRITE® Work Platform Ladders come in a range of standard sizes starting at a working height of 500 mm and increase in 250 mm intervals all the way up to our largest at 3 metres.



Can't find what you want?
Contact us at
+61 8 9270 0200 or
contactoem@oemgroup.com.au

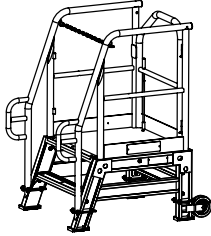

SWP500

Standard

Minespec

SMP500

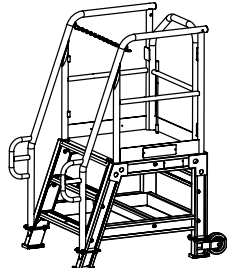

SWP750

SMP750

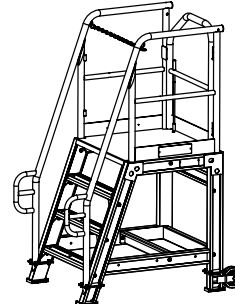

SWP1000

SMP1000

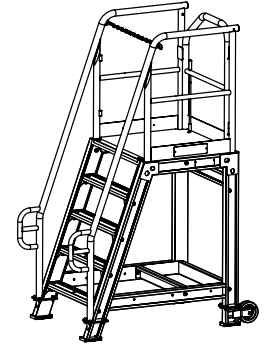

SWP1250

SMP1250

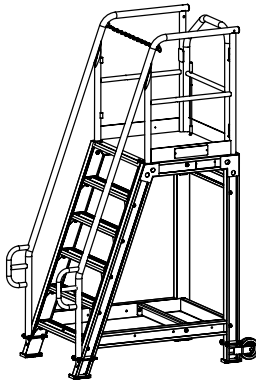

SWP1500

Standard

Minespec

SMP1500

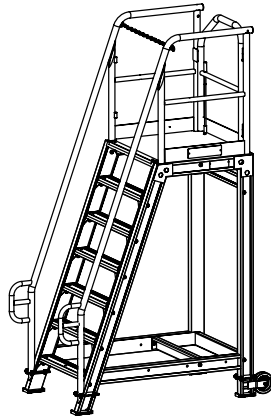

SWP1750

SMP1750

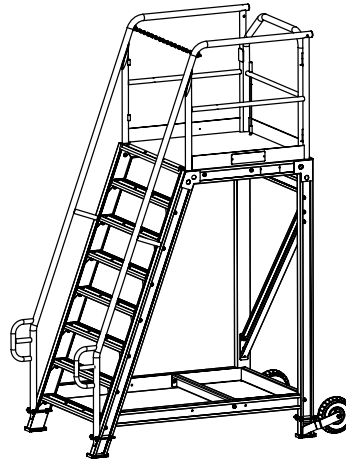

SWP2000

SMP2000

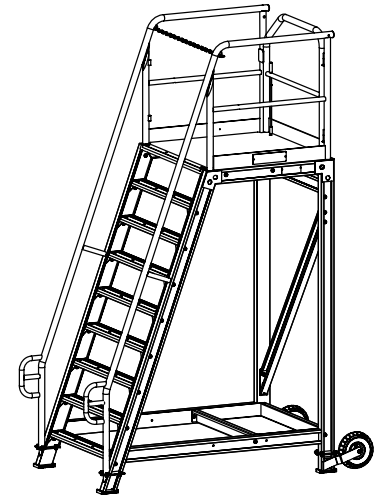

SWP2250

SMP2250

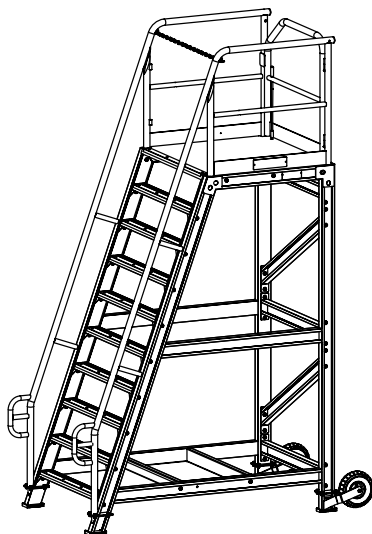

SWP2500

Standard

Minespec

SMP2500

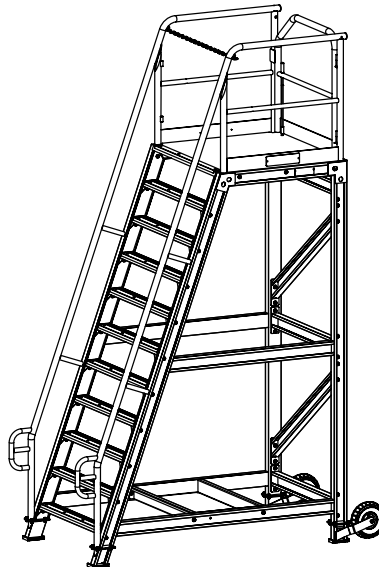

SWP2750

SMP2750

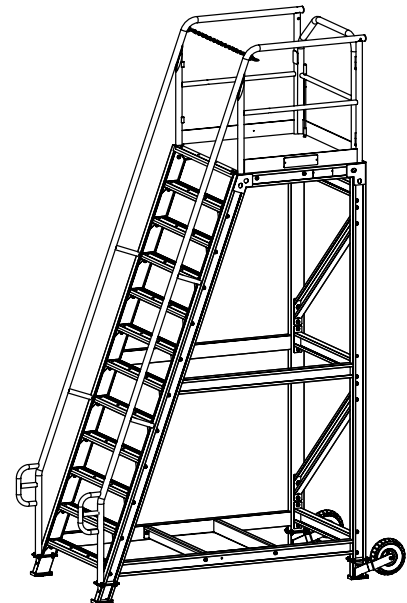

SWP3000

SMP3000



SWP2000 (Standard)



SMP1500 (Minespec)

1. SAFETY CHAIN & CLIPS

All work platform ladders come with strong fully welded safety chains and clips.

2. SAFETY GATE

All work platform ladders come with an inward opening safety gate, which can be locked in the open or closed position. This provides a kickplate all around the platform as required by Australian standards.

3. C-SECTION

Specifically designed lightweight 'C' section provides high strength and torsional resistance. It also allows all fixings to be concealed and not protrude where they could cause injuries or damage.

4. HANDRAIL

Seamless, fully-welded 915mm high handrail with midrail to ladders and platform.

5. FIXED WHEELS

For easy maneuverability.

6. FRAME DESIGN

Unique design allows the work platform ladders to be flat packed for easy cost-effective transport and storage. Each ladder comes with easy step-by-step installation instructions.

7. ANTI-SLIP

Special non-slip to improve onsite safety by assisting with the prevention of slips and falls.

8. LIFTING HANDLES

Conveniently placed lifting handles allows the unit to be moved around easily.

9. HEAVY-DUTY PLATFORM

Non-slip surface with 4.5mm thick plate for added strength and durability.

10. TOOL TRAY

Keep tools and equipment dry and clean using the included tool tray.

11. FEET

Large feet with non-slip rubber mouldings to provide a stable footing.

MINESPEC UPGRADE

12. BARN-STYLE SAFETY DOORS

One way self-closing barn style safety doors, with safety hinges and Safety Yellow paint.

13. BOOM-RAIL

Barrier to prevent access up to a controlled point.

14. FORKLIFT POCKETS

Providing a simple solution for the safe positioning of safety access platforms with a forklift.

OPTIONAL ACCESSORY

LOCKABLE SWIVEL WHEELS

Steprite Safety Access Platforms are available with optional lockable swivel wheels for ease of manoeuvrability.



BARN GATE



GATE



NON-SLIP STEPS



TOOL TRAY AND FORKLIFT ROCKETS

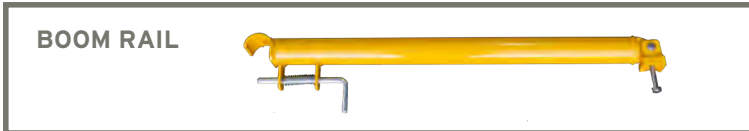

BOOM RAIL



FIXED FOOD AND FOAM FILLED WHEELS



SWIVEL WHEELS*

*Optional Extra

Whilst our standard range of Work Platforms can provide a quick and easy solution to your access needs, we understand that more specialised solutions are often required. STEPRITE® offers a design and manufacture service that will supply a tailor made access solution to suit your specific requirements. STEPRITE® Special Builds can include ladders or access stairs to platforms with fixed or removable handrailing options. Special widths, heights and configurations can be designed along with any access restrictions allowing use in and around or over equipment. A range of wheel style and materials along with extra handling options such as crane lifting points or forklift pockets are also available to assist in moving the ladders to the locations required.

All STEPRITE® Special Builds will be designed and manufactured to comply with relevant Australian Standards and any company specific codes or occupational health and safety requirements. Engineering certification and testing can be provided on request (at additional cost).

We also provide platforms built to mine specifications. These can be customised to suit your individual requirements.



WPL1250 with 6 Meter TSAP Extension

Made in WA TO AUSTRALIAN STANDARDS

AVIATION

Aircraft Platforms

Aircraft Maintenance Work Platform

- Anti-slip stairway and work area
- Safety handrails
- Lockable swivel wheels

Construction: Aluminum

Height: 2000mm

WLL: 250kg



Part No: OEM00001

Aircraft Maintenance Platform

- Anti-slip stairway and work area
- Safety handrails
- Lockable swivel wheels

Construction: Aluminum

Height: 2550mm

WLL: 250kg



Part No: OEM00024

Aircraft Oil Change Platform

- Tow arm
- Anti-slip stairway and work area
- Safety handrails
- Lockable swivel wheels

Construction: Steel

Height: 1185mm

WLL: 250kg



Part No: OEM00345

AVIATION

Aircraft Platforms



Aircraft Oil Change Platform

- Tow arm
- Hydraulic pump
- Anti-slip stairway and work area
- Safety handrails
- Wheels

Construction: Steel

Height: 1580mm

WLL: 250kg



Part No: OEM01209

Aviation Maintenance Platform

- Tow arm
- Jockey stand
- Anti-slip stairway and work area
- Safety handrails
- Lockable swivel wheels

Construction: Aluminum

Height: 1025mm - 1840mm

WLL: 250kg



Part No: OEM01236

Aircraft Wing Maintenance Platform

- Jockey stand
- Anti-slip stairway and work area
- Safety handrails
- Wheels

Construction: Aluminum

Height: 3070mm

WLL: 150kg



Part No: OEM01370

AVIATION

Aircraft Platforms



Rear Wing Platform

- Anti-slip stairway and work area
- Safety handrails
- Lockable swivel wheels

Construction: Aluminum

Height: 4000mm

WLL: 250kg



Part No: OEM00128

Aviation Rear Wing Access Platform

- Anti-slip stairway and work area
- Safety handrails
- Lockable swivel wheels

Construction: Aluminum

Height: 4750mm

WLL: 250kg



Part No: OEM01034

Baggage Door Platform

- Anti-slip stairway and work area
- Lockable swivel wheels

Construction: Aluminum

Height: 1500mm

WLL: 250kg



Part No: OEM01412



DESIGNED &

INDEPENDENTLY TESTED

AVIATION

Aircraft Platforms

Passenger Access Platform

- Tow arm and jockey stand
- Anti-slip stairway and work area
- Self-closing gates
- Safety handrails
- Lockable swivel wheels

Construction: Aluminum

Height: 4250mm

WLL: 250kg



Part No: OEM00147

Maintenance Access Platform

- Road wheels
- Jockey stand
- Anti-slip stairway and work area
- Safety handrails
- Lockable swivel wheels

Construction: Aluminum

Height: 2200mm

WLL: 750kg



Part No: OEM01190

Helicopter Maintenance Platform

- Flip up platform
- Counterweight
- Non-slip stairway and work area
- Safety handrails
- Lockable swivel wheels

Construction: Aluminum

Height: 805mm

WLL: 250kg



Part No: OEM00150



SAFETY ACCESS SOLUTIONS

BUILT FOR STRENGTH & DURABILITY

Made in WA TO AUSTRALIAN STANDARDS

AVIATION

Aircraft Platforms

Helicopter Maintenance Platform

- Lifting table
- Anti-slip stairway and work area
- Safety handrails
- Lockable swivel wheels

Construction: Aluminum

Height: 1600mm - 2400mm

WLL: 250kg

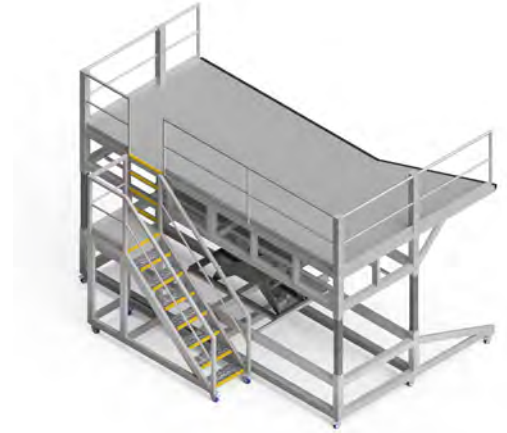

Part No: OEM00271

Helicopter Maintenance Platform

- Docking rubber
- Removable basket
- Anti-slip stairway and work area
- Safety handrails
- Lockable swivel wheels

Construction: Aluminum

Height: 1620mm

WLL: 250kg



Part No: OEM01274

Helicopter Maintenance Platform

- Anti-slip stairway and work area
- Safety handrails
- Lockable swivel wheels

Construction: Aluminum

Height: 2343mm

WLL: 250kg



Part No: OEM01404

AVIATION

Aircraft Maintenance



Aircraft Engine Hoist

- Jockey stand
- Lockable swivel wheels

Construction: Steel



Part No: OEM00002



Aviation Engine Lifting Jig

Construction: Steel

Part No: OEM00098a



Aviation Engine Lifting Jig

Construction: Steel

Part No: OEM00098b

Aviation Chock Trolley

Construction: Steel



Part No: OEM01309

LOCOMOTIVE

Locomotive Platforms

Loco Gen Pod Platform

- Anti-slip deck

Construction: Steel

Height: 700mm



Part No: OEM01195

Loco LSS Access Platform

- Anti-slip steps and work area
- Flip up platform

Construction: Aluminum

Height: 750mm

WLL: 130kg



Part No: OEM00876

Loco Maintenance Platform

- Swing platform
- Anti-slip stairway and work area
- Safety handrails
- Lockable swivel wheels

Construction: Aluminum

Height: 1210mm

WLL: 250kg



Part No: OEM00916

Loco HVAC Platform

- Jockey stand
- Anti-slip stairway and work area
- Self-closing gates
- Safety handrails
- Lockable swivel wheels

Construction: Aluminum

Forklift Slots: Yes

Height: 1750mm

WLL: 250kg



Part No: OEM01287

LOCOMOTIVE

Locomotive Platforms



Loco Brake Access Platform

- Jockey stand
- Anti-slip work area
- Safety handrails
- Lockable swivel wheels

Construction: Aluminum

Forklift Slots: Yes

Height: 1750mm

WLL: 250kg



Part No: OEM01288

Loco Aircon Access Platform

- Anti-slip stairway and work area
- Safety handrails
- Lockable swivel wheels

Construction: Aluminum

Height: 4050mm

WLL: 250kg



Part No: OEM01031

Loco Aircon Access Platform

- Anti-slip stairway and work area
- Self-closing gates
- Safety handrails
- Lockable swivel wheels

Construction: Aluminum

Forklift Slots: Yes

Height: 4055mm

WLL: 250kg



Part No: OEM00270

CRANE

Maintenance Platforms

Dual Access Crane Maintenance Platform

- Anti-slip stairway and work area
- Self-closing gates
- Safety handrails
- Lockable swivel wheels

Construction: Aluminum

Height: 1000mm

WLL: 250kg



Part No: OEM00962

Elevated Dual Access Crane Maintenance Platform

- Anti-slip stairway and work area
- Self-closing gates
- Safety handrails
- Lockable swivel wheels

Construction: Aluminum

Height: 1750mm

WLL: 250kg



Part No: OEM00964

Crane Maintenance Platform

- Anti-slip stairway and work area
- Self-closing gates
- Safety handrails
- Lockable swivel wheels

Construction: Aluminum

Height: 2250mm

WLL: 250kg



Part No: OEM00963

CRANE

Access Platforms



Maintenance Platform

- Anti-slip stairway and work area
- Safety handrails
- Lockable swivel wheels

Construction: Aluminum

Height: 1750mm

WLL: 250kg

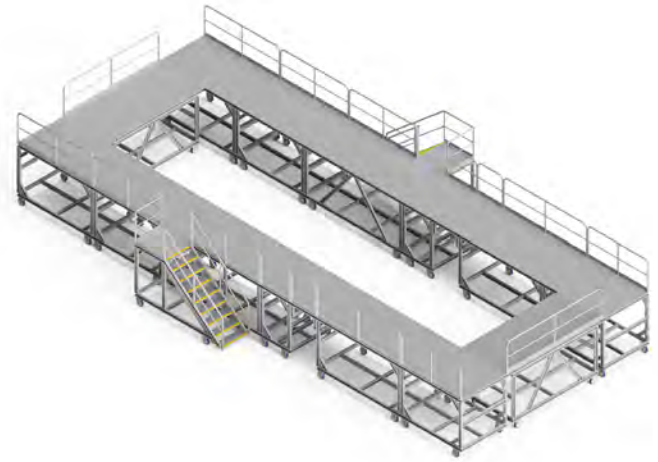

Part No: OEM00090

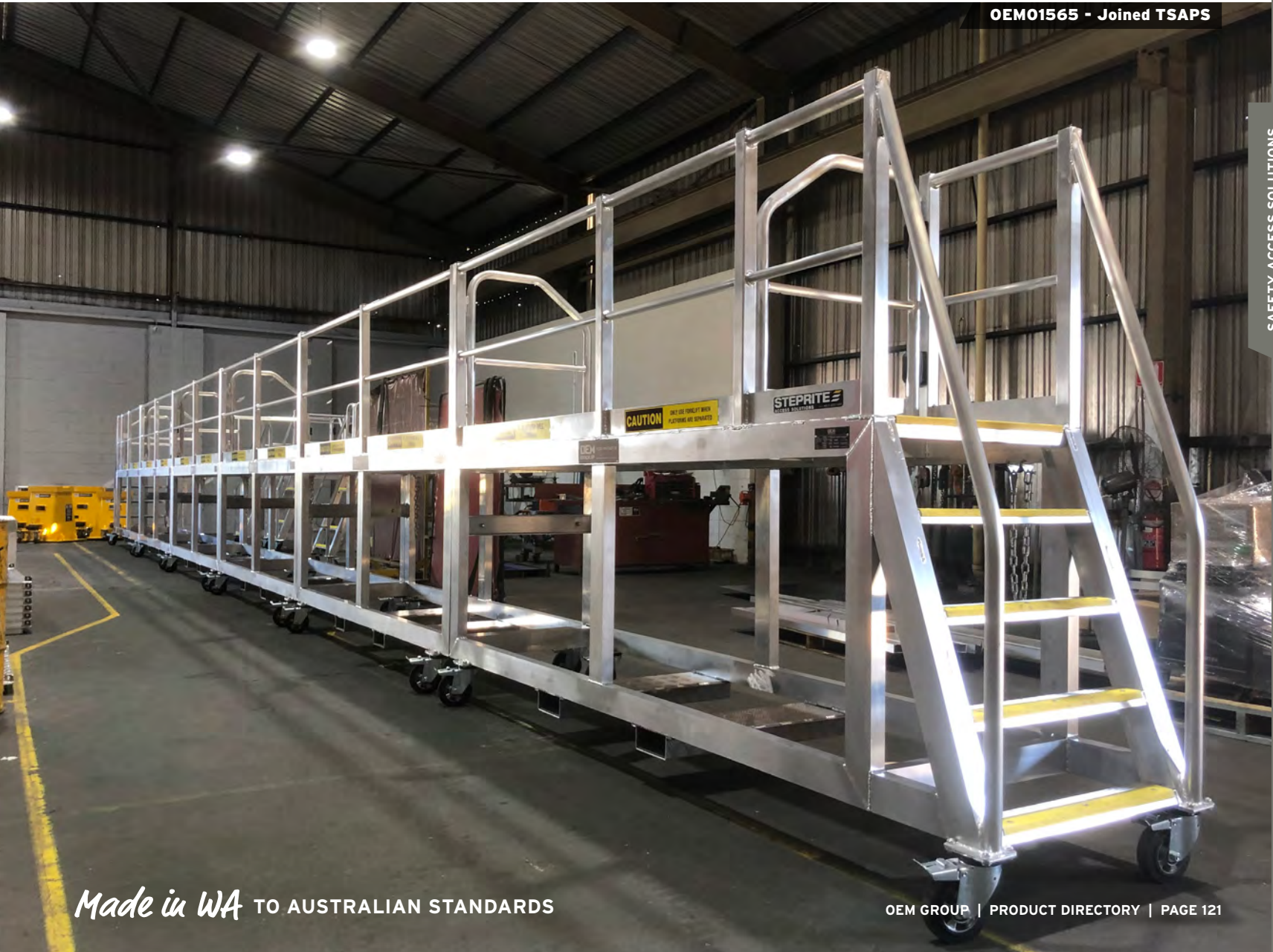

OEM01565 - Joined TSAPS

SAFETY ACCESS SOLUTIONS

Made in WA TO AUSTRALIAN STANDARDS

OIL & GAS

Stands, Accessories & Tools

Air Over Hydraulic Trolley

- Wheels

Construction: Aluminum

WLL: 5T



Part No: OEM00580

Turbine Trolley

- Wheels

Construction: Aluminum

Height: 655mm

WLL: 16T



Part No: OEM00952



OEM00580 - Air Over Hydraulic Trolley

OIL & GAS

Access Platforms



Fin Fan Changeout Platform

- Anti-slip stairway and work area
- Safety handrails
- Lockable swivel wheels
- Gates
- Jacking stand

Construction: Aluminum

WLL: 250kg



Part No: OEM00783

Fin Fan Changeout Platform

- Anti-slip stairway and work area
- Safety handrails
- Lockable swivel wheels
- Jockey stand

Construction: Aluminum/Steel

WLL: 1.5T



Part No: OEM00559

Top Fin Fan Maintenance Platform

- Anti-slip stairway and work area
- Safety handrails
- Self-closing gates
- Lockable swivel wheels

Construction: Aluminum/Steel

Height: 2920mm

WLL: 250kg



Part No: OEM00556



4001545



TRANSPORT

Tipper Body Props

Construction: Aluminum
WLL: 4T

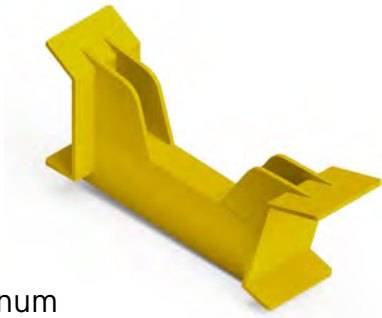

Part No: OEM00351



Part No: OEM00352



Part No: OEM00400

OEM01456 - OEM Group Transport Safety Access Platform



WASH DOWN BAY PLATFORMS



Wash Down Bay Access Platform

- Anti-slip stairway and work area
- Safety handrails

Construction: Steel

Height: 3000mm

WLL: 250kg



Part No: OEM01158

Wash Down Bay Access Platform

- Anti-slip stairway and work area
- Safety handrails

Construction: Aluminum

Height: 4500mm

WLL: 250kg

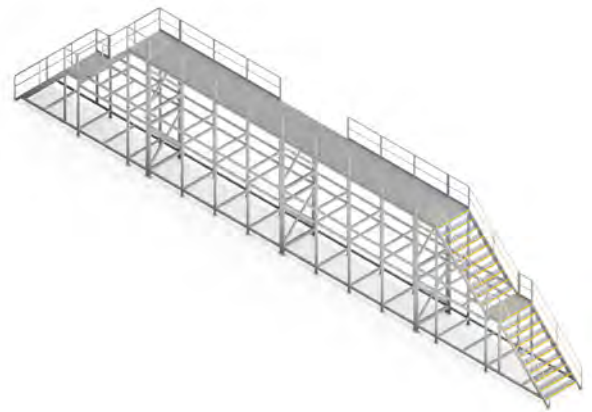

Part No: OEM01083

SAFETY ACCESS SOLUTIONS



Wash Bay Safety Access Platform and Spitwater SHW88

Made in WA TO AUSTRALIAN STANDARDS

05

INDUSTRIAL CLEANING SOLUTIONS

Industrial Pressure Cleaners - <i>SPITWATER</i>	130 - 145
Industrial Heaters - <i>JETFIRE</i>	146 - 149
Industrial Vacuum Cleaners - <i>VACSTORM</i>	150 - 152
Industrial Floor Scrubbers	153
Mounted Pressure Cleaners - Trailers, Trucks & Utes	154 - 156
Tailor-Made Cleaning Solutions	157 - 158
Ultra High Pressure Cleaner Training	159



INDUSTRIAL PRESSURE CLEANERS - SPITWATER

Electric Pressure Cleaners - Cold Water

MODEL: HP10090

Pump Pressure (PSI): 1350
Litres per minute: 10
Power Type: Single Phase 10 Amp
Motor (HP): 2
Industry: Professional

Part No: SCW76



MODEL: HP110

Pump Pressure (PSI): 1650
Litres per minute: 12
Power Type: Single Phase 15 Amp
Motor (HP): 3
Industry: Industrial

Part No: SCW70

MODEL: HP151

Pump Pressure (PSI): 2250
Litres per minute: 14
Power Type: Three Phase 20 Amp
Motor (HP): 5.5
Industry: Industrial

Part No: SCW69

MODEL: HP201

Pump Pressure (PSI): 3000
Litres per minute: 15
Power Type: Three Phase 20 Amp
Motor (HP): 7.5
Industry: Industrial

Part No: SCW53

MODEL: HP201S

Pump Pressure (PSI): 3000
Litres per minute: 21
Power Type: Three Phase 20 Amp
Motor (HP): 10
Industry: Industrial

Part No: SCW54



Can't find what you want?
Contact us at
+61 8 9270 0200 or
contactoem@oemgroup.com.au

INDUSTRIAL PRESSURE CLEANERS - SPITWATER

Electric Pressure Cleaners - Cold Water Wall Mounted Models

MODEL: HT1111

Pump Pressure (PSI): 1650
Litres per minute: 11
Power Type: Single Phase 15 Amp
Motor (HP): 3
Accepts temperature: Up to 80°C
Industry: Industrial



Part No: SCW82/G



MODEL: HP12110E GT

Pump Pressure (PSI): 1650
Litres per minute: 12
Power Type: Single Phase 15 Amp
Motor (HP): 3
Industry: Industrial

Part No: SCW70/G

MODEL: HT18160E GT

Pump Pressure (PSI): 2400
Litres per minute: 18
Power Type: Three Phase 20 Amp
Motor (HP): 7.5
Accepts temperature: Up to 80°C
Industry: Industrial



Part No: SCW83/G

MODEL: HP15200E GT

Pump Pressure (PSI): 3000
Litres per minute: 15
Power Type: Three Phase 20 Amp
Motor (HP): 7.5
Industry: Industrial

Part No: SCW53/G

MODEL: HP21200E GT

Pump Pressure (PSI): 3000
Litres per minute: 21
Power Type: Three Phase 20 Amp
Motor (HP): 10
Industry: Industrial

Part No: SCW54/G

INDUSTRIAL PRESSURE CLEANERS - SPITWATER

Electric Pressure Cleaners - Cold Water

MODEL: 10-120C

Pump Pressure (PSI): 1800

Litres per minute: 10

Power Type: Single Phase 15 Amp

Motor (HP): 3

Industry: Commercial



Part No: SLD10



MODEL: HP2030

Pump Pressure (PSI): 3000

Litres per minute: 30

Power Type: Three Phase 32 Amp

Motor (HP): 15

Industry: Industrial

Part No: SCW85

MODEL: HP3523

Pump Pressure (PSI): 5000

Litres per minute: 23

Power Type: Three Phase 32 Amp

Motor (HP): 20

Industry: Industrial

Part No: SCW86



Can't find what you want?
Contact us at
+61 8 9270 0200 or
contactoem@oemgroup.com.au

INDUSTRIAL PRESSURE CLEANERS - SPITWATER

Electric Pressure Cleaners - Cold Water

MODEL: SWC100

Pump Pressure (PSI): 4500
Litres per minute: 50
Power Type: Three Phase 64 Amp
Motor (HP): 40
Industry: Industrial

Part No: SCW11



MODEL: HP36400E

Pump Pressure (PSI): 5800
Litres per minute: 36
Power Type: Three Phase 63 Amp
Motor (HP): 50
Industry: Industrial

Part No: SCW14

MODEL: HP47400E

Pump Pressure (PSI): 5800
Litres per minute: 47
Power Type: Three Phase 63 Amp
Motor (HP): 50
Industry: Industrial

Part No: SCW18

MODEL: HP4025

Pump Pressure (PSI): 6000
Litres per minute: 25
Power Type: Three Phase 32 Amp
Motor (HP): 25
Industry: Industrial

Part No: SCW12

MODEL: HP5015

Pump Pressure (PSI): 7250
Litres per minute: 15
Power Type: Three Phase 63 Amp
Motor (HP): 50
Industry: Industrial

Part No: SCW87



Can't find what you want?
Contact us at
+61 8 9270 0200 or
contactoem@oemgroup.com.au

INDUSTRIAL PRESSURE CLEANERS - SPITWATER

Electric Pressure Cleaners - Cold Water

MODEL: HP30500E

Pump Pressure (PSI): 7250
Litres per minute: 30
Power Type: Three Phase 63 Amp
Motor (HP): 50
Industry: Industrial

Part No: SCW15



MODEL: HP38500E

Pump Pressure (PSI): 7250
Litres per minute: 38
Power Type: Three Phase 63 Amp
Motor (HP): 50
Industry: Industrial

Part No: SCW19

MODEL: HP30600E

Pump Pressure (PSI): 8700
Litres per minute: 30
Power Type: Three Phase 63 Amp
Motor (HP): 50
Industry: Industrial

Part No: SCW17

SHW88 & WPL1750 - Spitwater Pressure Cleaner & Steprite Standard Access Platform



ONLY THE HIGHEST QUALITY PRODUCTS



INDUSTRIAL PRESSURE CLEANERS - SPITWATER

Electric Pressure Cleaners - **Hot Water**



MODEL: 10-120H

Pump Pressure (PSI): 1800
Litres per minute: 10
Power Type: Single Phase 15 Amp
Motor (HP): 3
Industry: Commercial

Part No: SLD09

MODEL: 13-180H

Pump Pressure (PSI): 2700
Litres per minute: 13
Power Type: Three Phase 20 Amp
Motor (HP): 5.5
Industry: Commercial

Part No: SLD08

MODEL: SW2030

Pump Pressure (PSI): 3000
Litres per minute: 30
Power Type: Three Phase 32 Amp
Motor (HP): 15
Industry: Industrial



Part No: SHW85



Can't find what you want?
Contact us at
+61 8 9270 0200 or
contactoem@oemgroup.com.au

INDUSTRIAL PRESSURE CLEANERS - SPITWATER

Electric Pressure Cleaners - Hot Water



MODEL: SW110

Pump Pressure (PSI): 1650
Litres per minute: 12
Power Type: Single Phase 15 Amp
Motor (HP): 3
Industry: Industrial

Part No: SHW76-AS

MODEL: SW151

Pump Pressure (PSI): 2250
Litres per minute: 14
Power Type: Three Phase 20 Amp
Motor (HP): 5.5
Industry: Industrial

Part No: SHW68-S

MODEL: SW201

Pump Pressure (PSI): 3000
Litres per minute: 15
Power Type: Three Phase 20 Amp
Motor (HP): 7.5
Industry: Industrial

Part No: SHW69-S

MODEL: SW2021

Pump Pressure (PSI): 3000
Litres per minute: 21
Power Type: Three Phase 20 Amp
Motor (HP): 10
Industry: Industrial

Part No: SHW78-S

INDUSTRIAL PRESSURE CLEANERS - SPITWATER



Can't find what you want?
Contact us at
+61 8 9270 0200 or
contactoem@oemgroup.com.au

Petrol Pressure Cleaners - Cold Water

MODEL: HE15250P

Pump Pressure (PSI): 3650
Litres per minute: 15
Power Type: Petrol
Motor (HP): 13
Industry: Professional



Part No: SCWA67

MODEL: HC11140P

Pump Pressure (PSI): 2100
Litres per minute: 11
Power Type: Petrol
Motor (HP): 5.5
Industry: Domestic



Part No: SLD25

MODEL: HC12180P

Pump Pressure (PSI): 2600
Litres per minute: 12
Power Type: Petrol
Motor (HP): 6.5
Industry: Commercial



Part No: SLD24

MODEL: HE13200P

Pump Pressure (PSI): 3000
Litres per minute: 13
Power Type: Petrol
Motor (HP): 9
Industry: Professional

Part No: SCWA68

MODEL: HC15275P

Pump Pressure (PSI): 4000
Litres per minute: 15
Power Type: Petrol
Motor (HP): 13
Industry: Commercial

Part No: SLD19



BUILT TOUGH FOR
AUSSIE CONDITIONS

INDUSTRIAL PRESSURE CLEANERS - SPITWATER

Petrol Pressure Cleaners - Cold Water

MODEL: HP201/SAE

Pump Pressure (PSI): 3000
Litres per minute: 21
Power Type: Petrol
Motor (HP): 13 - Electric Start
Industry: Industrial

Part No: SCWA62



MODEL: HP251/A

Pump Pressure (PSI): 3650
Litres per minute: 15
Power Type: Petrol
Motor (HP): 13
Industry: Industrial

Part No: SCWA60

MODEL: HP251/AE

Pump Pressure (PSI): 3650
Litres per minute: 15
Power Type: Petrol
Motor (HP): 13 - Electric Start
Industry: Industrial

Part No: SCWA60/A



SHW88/A - Diesel Hot Water Pressure Cleaning Trailer

HIRE OR BUY

INDUSTRIAL PRESSURE CLEANERS - SPITWATER



Can't find what you want?
Contact us at
+61 8 9270 0200 or
contactoem@oemgroup.com.au

Petrol Pressure Cleaners - Cold Water

MODEL: HP2430/AE

Pump Pressure (PSI): 3500

Litres per minute: 30

Power Type: Petrol

Motor (HP): 20

Industry: Industrial

Part No: SCWA63



COLD WATER



PETROL

MODEL: HP251/SAE

Pump Pressure (PSI): 3650

Litres per minute: 21

Power Type: Petrol

Motor (HP): 20

Industry: Industrial

Part No: SCWA61

MODEL: HP3523/AE

Pump Pressure (PSI): 5000

Litres per minute: 23

Power Type: Petrol

Motor (HP): 22

Industry: Industrial

Part No: SCWA64



SCWA63 - Spitwater Petrol Pressure Cleaner

INDUSTRIAL PRESSURE CLEANERS - SPITWATER

Petrol Pressure Cleaners - Hot Water

MODEL: SW15200PE

Pump Pressure (PSI): 3000

Litres per minute: 15

Power Type: Petrol

Motor (HP): 13

Industry: Industrial



Part No: SHW89

MODEL: SW21200PE

Pump Pressure (PSI): 3000

Litres per minute: 21

Power Type: Petrol

Motor (HP): 20

Industry: Industrial



Part No: SHW90



Spitwater Specialised Foaming Accessory

HIRE OR BUY

INDUSTRIAL PRESSURE CLEANERS - SPITWATER

Diesel Pressure Cleaners - Cold Water



Can't find what you want?
Contact us at
+61 8 9270 0200 or
contactoem@oemgroup.com.au

MODEL: HP12150DE

Pump Pressure (PSI): 2250

Litres per minute: 12

Power Type: Diesel

Motor (HP): 6.5

Industry: Industrial

Part No: SCWD062



MODEL: HP15210DE

Pump Pressure (PSI): 3050

Litres per minute: 15

Power Type: Diesel

Motor (HP): 9.5

Industry: Industrial

Part No: SCWD067

SHW76-A - Spitwater Hot Water Pressure Cleaner



INDUSTRIAL PRESSURE CLEANERS - SPITWATER

Diesel Pressure Cleaners - Cold Water

MODEL: HP30250DE

Pump Pressure (PSI): 3650

Litres per minute: 30

Power Type: Diesel

Motor (HP): 23.5

Industry: Industrial

Part No: SCWD082



MODEL: HP23350DE

Pump Pressure (PSI): 5000

Litres per minute: 23

Power Type: Diesel

Motor (HP): 23.5

Industry: Industrial

Part No: SCWD084



SHW76-A - Spitwater Hot Water Pressure Cleaner



Can't find what you want?
Contact us at
+61 8 9270 0200 or
contactoem@oemgroup.com.au

INDUSTRIAL PRESSURE CLEANERS - SPITWATER

Diesel Pressure Cleaners - Hot Water

MODEL: SW15200DE

Pump Pressure (PSI): 3000

Litres per minute: 15

Power Type: Diesel

Motor (HP): 9.5

Industry: Industrial



Part No: SHW87

MODEL: SW15200DES

Pump Pressure (PSI): 3000

Litres per minute: 15

Power Type: Diesel

Motor (HP): 8

Industry: Industrial



Part No: SHW91

MODEL: SW21200DE

Pump Pressure (PSI): 3000

Litres per minute: 21

Power Type: Diesel

Motor (HP): 23.5

Industry: Industrial



Part No: SHW88

INDUSTRIAL HEATERS

- JETFIRE

Direct Fired Diesel Area Heaters

MODEL: DC17

Heat Output (kW): 17
Fuel Consumption (L/Hr): 1.37
Electrical Supply: 240V - 10 Amp Plug
Fuel Tank Capacity (L): 19
Air Flow (m³/h): 357



Part No: JDDC017K

MODEL: DC30

Heat Output (kW): 30
Fuel Consumption (L/Hr): 2.4
Electrical Supply: 240V - 10 Amp Plug
Fuel Tank Capacity (L): 38
Air Flow (m³/h): 765

Part No: JDDC030K

Jetfire's diesel heaters come in ranges of direct, indirect and radiant models. Jetfire heaters are specifically designed to provide instant, reliable heating. Suitable for a range of industries, to optimise your productivity.

MODEL: DC50

Heat Output (kW): 50
Fuel Consumption (L/Hr): 4.12
Electrical Supply: 240V - 10 Amp Plug
Fuel Tank Capacity (L): 49
Air Flow (m³/h): 1036

Part No: JDDC050K



INDUSTRIAL HEATERS

- JETFIRE



Direct Fired Diesel Area Heaters



MODEL: DP65

Heat Output (kW): 69.3
Fuel Consumption (L/Hr): 5.48
Electrical Supply: 230V - 15 Amp Plug
Fuel Tank Capacity (L): 65
Air Flow (m³/h): 2500

Part No: JDDP065I

MODEL: DP105

Heat Output (kW): 111.1
Fuel Consumption (L/Hr): 8.85
Electrical Supply: 230V - 15 Amp Plug
Fuel Tank Capacity (L): 105
Air Flow (m³/h): 4600

Part No: JDDP105I

Indirect Fired Diesel Area Heaters



MODEL: IP32

Heat Output (kW): 28.9
Fuel Consumption (L/Hr): 2.7
Electrical Supply: 230V - 15 Amp Plug
Fuel Tank Capacity (L): 42
Air Flow (m³/h): 1150

Part No: JDIP032I



MODEL: IP110

Heat Output (kW): 71.2
Fuel Consumption (L/Hr): 6.33
Electrical Supply: 230V - 15 Amp Plug
Fuel Tank Capacity (L): 135
Air Flow (m³/h): 5300

Part No: JDIP110I

INDUSTRIAL HEATERS - JETFIRE



Can't find what you want?
Contact us at
+61 8 9270 0200 or
contactoem@oemgroup.com.au

Radiant Heat Diesel Area Heaters



RADIANT
HEAT

DIESEL

MODEL: DI16

Heat Output (kW): 16.5

Fuel Consumption (L/Hr): 1.37

Electrical Supply: 230V - 10 Amp Plug

Fuel Tank Capacity (L): 13

Part No: JDDI016K

Direct Fired LPG Area Heaters



DIRECT
FIRED

LPG

MODEL: J20A

Heat Output (kW): 17.9

Fuel Type: Universal LPG

Electrical Supply: Single Phase - 10 AMP

Ignition Type: Automatic

Part No: JGDA020I



DIRECT
FIRED

LPG

MODEL: J45A

Heat Output (kW): 36.1

Fuel Type: Universal LPG

Electrical Supply: Single Phase - 10 AMP

Ignition Type: Automatic

Part No: JGDA045I



RELIABLE &

EFFICIENT SOURCE

OF HEATING

INDUSTRIAL VACUUM CLEANERS

Dry Vacuum Cleaners

VACSTORM AS5

Max. Power Rating (W): 1000

Container Capacity (L): 7

Useful Capacity (L): 5

Filter Surface (m²): N/A

Air Flow (L/s): 53



Part No: SP45

Wet & Dry Vacuum Cleaners

VACSTORM ASL10

Max. Power Rating (W): 1000

Container Capacity (L): 13

Useful Capacity (L): 10

Filter Surface (m²): 0.4

Air Flow (L/s): 53



Part No: SP55

VACSTORM AS27

Max. Power Rating (W): 1000

Container Capacity (L): 38

Useful Capacity (L): 27

Filter Surface (m²): 0.4

Air Flow (L/s): 53

Part No: SP57

VACSTORM AS400

Max. Power Rating (W): 1200

Container Capacity (L): 50

Useful Capacity (L): 35

Filter Surface (m²): 0.4

Air Flow (L/s): 53

Part No: SP98

INDUSTRIAL VACUUM CLEANERS

Wet & Dry Vacuum Cleaners



Can't find what you want?
Contact us at
+61 8 9270 0200 or
contactoem@oemgroup.com.au

Our range of commercial cleaners includes heavy-duty industrial machines, with all steel construction and advanced design features to exceed industrial workshop standards.



VACSTORM AS59/M

Max. Power Rating (W): 2000
Container Capacity (L): 75
Useful Capacity (L): 58
Filter Surface (m²): 0.4
Air Flow (L/s): 106

Part No: SP65

VACSTORM AS59/CBE

Max. Power Rating (W): 2000
Container Capacity (L): 75
Useful Capacity (L): 58
Filter Surface (m²): 0.4
Air Flow (L/s): 106

Part No: SP77/A

VACSTORM AS60 IK

Max. Power Rating (W): 3000
Container Capacity (L): 75
Useful Capacity (L): 58
Filter Surface (m²): 0.4
Air Flow (L/s): 159

Part No: SP78/A

VACSTORM AS600 IK CBM

Max. Power Rating (W): 3000
Container Capacity (L): 75
Useful Capacity (L): 58
Filter Surface (m²): 0.4
Air Flow (L/s): 159

Part No: SP81/A

INDUSTRIAL VACUUM CLEANERS

Wet Pump-Out Vacuum Cleaners

VACSTORM WD80.2 P CF

Max. Power Rating (W): 2650
Container Capacity (L): 80
Useful Capacity (L): 42
Filter Surface (m²): N/A
Air Flow (L/s): 115



Part No: SP86

Shampoo Extraction Vacuum Cleaners

VACSTORM M26

Max. Power Rating (W): 2100
Container Capacity (L): N/A
Useful Capacity (L): 58
Filter Surface (m²): N/A
Air Flow (L/s): 106



Part No: EX39



VS001F - Freccia 15E 38 Electric Floor Scrubber

INDUSTRIAL FLOOR SCRUBBERS



Freccia 15 E 38

Brush Width: 385mm
Squeegee Width: 450mm
Clean Water Capacity (L): 15
Recover Water Capacity (L): 17
Theoretical Performance (m²/Hr): 1540
Battery Life: N/A

Part No: VS001F



Freccia 15 M 38BC

Brush Width: 385mm
Squeegee Width: 450mm
Clean Water Capacity (L): 15
Recover Water Capacity (L): 21
Theoretical Performance (m²/Hr): 1540
Battery Life: 1 Hour

Part No: VS002F

Freccia 15 M 38BC Long Run

Brush Width: 385mm
Squeegee Width: 450mm
Clean Water Capacity (L): 15
Recover Water Capacity (L): 21
Theoretical Performance (m²/Hr): 1540
Battery Life: 2 Hours

Part No: VS003F

Freccia 30 M 45 C BC

Brush Width: 430mm
Squeegee Width: 650mm
Clean Water Capacity (L): 30
Recover Water Capacity (L): 33
Theoretical Performance (m²/Hr): 1720
Battery Life: 2 Hours

Part No: VS005



Round 45 D 60 BC Chem

Brush Width: 600mm
Squeegee Width: 750mm
Clean Water Capacity (L): 45
Recover Water Capacity (L): 47
Theoretical Performance (m²/Hr): 1720
Battery Life: 3 Hours

Part No: VS006FT

MOUNTED PRESSURE CLEANERS - TRAILERS, TRUCKS & UTES

Petrol Trailer Mounted Pressure Cleaners

Wombat JETTER Trailer

Pump Pressure (PSI): 5000

Litres per minute: 23

Power Type: Petrol

Motor (HP): 24

Industry: Industrial



Part No: SCWA64/JT



Hottie IV-P

Pump Pressure (PSI): 3000

Litres per minute: 15

Power Type: Petrol

Motor (HP): 13

Water Tank: 1000 Litres

Industry: Industrial

Part No: SHW89/A

Hottie V-P

Pump Pressure (PSI): 3000

Litres per minute: 21

Power Type: Petrol

Motor (HP): 20

Water Tank: 1000 Litres

Industry: Industrial

Part No: SHW90/A



Can't find what you want?
Contact us at
+61 8 9270 0200 or
contactoem@oemgroup.com.au

MOUNTED PRESSURE CLEANERS - TRAILERS, TRUCKS & UTES

Diesel Trailer Mounted Pressure Cleaners

MODEL: TSA15210DET

Pump Pressure (PSI): 3000
Litres per minute: 15
Power Type: Diesel
Motor (HP): 9.5
Water Tank: 1000 Litres
Industry: Industrial



Part No: SCWD067/A



Hottie IV-D

Pump Pressure (PSI): 3000
Litres per minute: 15
Power Type: Diesel
Motor (HP): 9.5
Water Tank: 1000 Litres
Industry: Industrial

Part No: SHW87/A

Hottie V-D

Pump Pressure (PSI): 3000
Litres per minute: 21
Power Type: Diesel
Motor (HP): 23.5
Water Tank: 1000 Litres
Industry: Industrial

Part No: SHW88/A

HIRE OR BUY

MOUNTED PRESSURE CLEANERS - TRAILERS, TRUCKS & UTES



Can't find what you want?
Contact us at
+61 8 9270 0200 or
contactoem@oemgroup.com.au

Diesel Trailer Mounted Pressure Cleaners

Workmate Hottie

Pump Pressure (PSI): 3000

Litres per minute: 15

Power Type: Diesel

Motor (HP): 9.5

Water Tank: 1000 Litres

Industry: Industrial



Part No: SHW99/A



SHW99/A - Workmate Hottie

HIRE OR BUY

TAILOR-MADE CLEANING SOLUTIONS



Can't find what you want?
Contact us at
+61 8 9270 0200 or
contactoem@oemgroup.com.au

With in-house design, engineering and fabrication expertise, we can custom-design a pressure cleaner to perfectly suit your needs.

We are the specialists in creating tailor-made machines, included trailer mounted pressure cleaners (or on skids), complete with access platforms, and on board water tanks.

You can see just a few of the many examples of custom built pressure cleaners below.

If you have a unique application and require a tailor made solution - including extra high pressure - please contact us to discuss a custom-made pressure cleaner.



**SHW89/U - Vehicle Mounted Spitwater SW15200PE
Hot Water Petrol Pressure Cleaner**



**SCS54/3 - Cold Water Electric Machine Used in
Marine Industry to Clear Pathways for Augur Robot**



**SHDT067/2 - Hot Water Diesel Pressure Cleaner Trailer
Used in Port Quarantine**



**SCWD067/250 - Skid Mounted Spitwater Cold Water
Diesel Pressure Cleaner with 250L Water Supply**



TAILOR-MADE ENGINEERING SOLUTIONS

ULTRA HIGH PRESSURE CLEANER TRAINING

At the OEM Group we are working to improve the level of training to optimise the productivity and improve the safety of our clients. We are doing this by partnering with Site Skills Training in the introduction of a new high pressure cleaner training course.

Pressure washers are becoming an increasing part of commercial and industrial operations as the benefits of pressure cleaning become better known.

Conventional cleaning that would normally take a large amount of time energy and sometimes even special access equipment for larger items, can be done easily and simply and even be scrubbed from a distance with a high pressure cleaner in a fraction of the time.

We are proud to be working with Site Skills Australia to achieve greater safety and productivity on site.

Completed at the OEM Group facility, the training is conducted by experienced trainers from Site Skills Australia, one of Australia's leading providers of industry training.

The course has no prerequisites and is conducted over a period of two days. Upon completion students will not only have technical competence with high pressure jetting, but also be better prepared for safe operation within a worksite which may not be familiar. Students will work to achieve four units of competence.

Find out more on our website.



06

SPECIALISED SERVICES

Onsite 3D Scanning	162 - 163
Asset Management	164 - 165
Service & Repair	166 - 167
Long or Short Term Hire	168 - 169
Customised Projects	170 - 173



ONSITE 3D SCANNING



OEM Group offers the latest in Onsite 3D scanning services for a non-contact, cost effective and more accurate digitalising of physical objects to reverse engineer custom design engineering solutions for your business - on time and within budget.





Our trained and experienced staff use the **FARO FOCUS 70 Laser Scanner** to collect all physical measurements from the surface of any physical object or environment. Our scanners are accurate to several millimetres depending on the resolution of the scan to reduce time spent measuring in-field. They are made with a class 1 laser and are safe to look at to reduce risk.

From this collected data, OEM Group can create a high-quality, 3-dimensional digital colour visualisation of the physical object on screen - from large scale rooms, to products, to even mobile equipment.

Our expert in-house drafts team develop 3D modelling of a fit-for-purpose, innovative engineering solution. These can include custom design tools, jacking stands, pressure cleaners, access platforms, and maintenance solutions, suitable for difficult and complex areas for a variety of services and industries.

Our skilled fabrication team will then create the innovative solution to the exact width, height, and weight configurations of the custom design to solve your unique request. Our extensive and innovative skills portfolio also include specialised aluminium welding and fabrication.

OEM Group offer our 3D Scanning services Australia wide and if possible, we will visit your site to analyse the challenge firsthand.

We complete all our design and manufacturing in-house at our Perth location.

Contact us

Contact our Engineering team today to discover why we are your partner in productivity.

ASSET MANAGEMENT



OEM Group's asset management is setup as a one stop shop, to take away all the hassle and work involved in maintaining all safety access and jacking stand equipment. Designed to reduce equipment failure, downtime and improve safety cost efficiency and productivity, OEM Groups Asset management is formed of several key areas.

Accurate Quarterly Auditing

Each quarter, one of OEM Group's qualified inspectors, trained to identify all equipment on site, certify safety and work independently minimising disruptions, visits the site, and conducts rigorous inspections on each piece of equipment. Inspections include, equipment status, availability and quantified and quoted repairs and photos. Individual inspections are uploaded to a secure online portal each day.

Onsite Repairs

OEM Group inspectors are specifically trained to be able to offer onsite maintenance and repairs to damaged platform and jacking stands, preventing costly downtime and problems relating to damaged equipment.

Assets that are deemed unrepairable are isolated and tagged to prevent use. Details are provided in the quarterly report.

Detailed Reporting

Customers are supplied with quarterly reports from OEM Group as part of the Asset Management. These reports highlight asset utilisation, status and the impact and effects over time. These reports can be customised by OEM Group, to meet the clients individual requirements.

Secure Online Portal

Every Inspection along with photos and other information, is uploaded to a secure online portal, giving the customer, accurate clear information on the state and status of equipment. OEM Group updates this portal regularly with each day of inspections and utilises this information to supply the customer with their quarterly reports.



INCREASING

ASSET AVAILABILITY



TAKING CARE OF **WHAT'S IMPORTANT**

SERVICE & REPAIR



We offer servicing, maintenance agreements and repairs for every brand of pressure cleaners and Jetter. It's not just pressure cleaners either, we offer servicing and repairs for area heaters, and industrial vacuums as well.

Optimising Productivity

Our mission is to improve your on-site productivity. We have specifically designed our servicing and maintenance agreements to service the customer. The intention is to take away the stress, reducing the equipment downtime & prevent costly repairs. No need to book your service, we do that for you - we calculate how often your machine requires servicing and will contact you to schedule routine maintenance to ensure your pressure cleaner is always at its peak performance and giving you a longer lasting pressure cleaner.

Ready & Mobile

Our team of expert technicians can service your pressure cleaners, space heaters or industrial vacuums onsite, at our workshop in Perth or our new location in Karratha.

We also offer mobile services, our technicians come to you, The OEM Group service vehicles carry a huge range of pressure cleaner parts so maintenance can be performed entirely onsite for your convenience, and to reduce your downtime. It saves you time and freight back & forth to the workshop. While your pressure cleaner is being serviced, we can offer you short term hire should you need one from a choice of several pressure cleaners.

WA Wide

Our Perth showroom and workshop are located just 9km out of the Perth CBD.

We are extremely excited with the launch of our new facility in the Pilbara at Karratha.

Additionally, we have several distributors across the state.

All our facilities & distributors are here to assist in servicing and sales of machines and parts.



WE CAN

COME TO YOU

SCW70/G - Wall Mounted Electric Spitwater Pressure Cleaner



LONG OR SHORT TERM HIRE



We have a huge range of Spitwater pressure cleaners available for hire at incredibly affordable and flexible rental terms. 80% of our hire fleet is brand new which gives you the latest and greatest technology.

Competitive Prices

OEM Group are your local pressure cleaner experts. We offer competitive pricing on our hire agreements, so you can always be sure you are getting the best price on your machine.

By hiring equipment, you can save on capital and get the gear now. Hire equipment is also fully tax deductible, putting your hard earned money back in your pocket.

As your business grows, you can simply extend or upgrade your plan.

New Machines

80% of our hire fleet are brand new machines, so you will always have the best quality pressure cleaner for the job without the price tag.

We have a huge range of pressure cleaners from cold and hot water, to commercial and industrial and even trailer-mounted machines available to increase your productivity.

Included Service

All our machines are fully serviced and maintenance costs are covered during your hire agreement giving you less downtime.

Our expert technicians will keep your hire machine working at peak performance to increase your productivity.

Huge Range

All our Spitwater pressure cleaners are available for long term hire and a select range are available for short term hire.

If you're not sure what pressure cleaner is right for you, our team of experts can assist you.

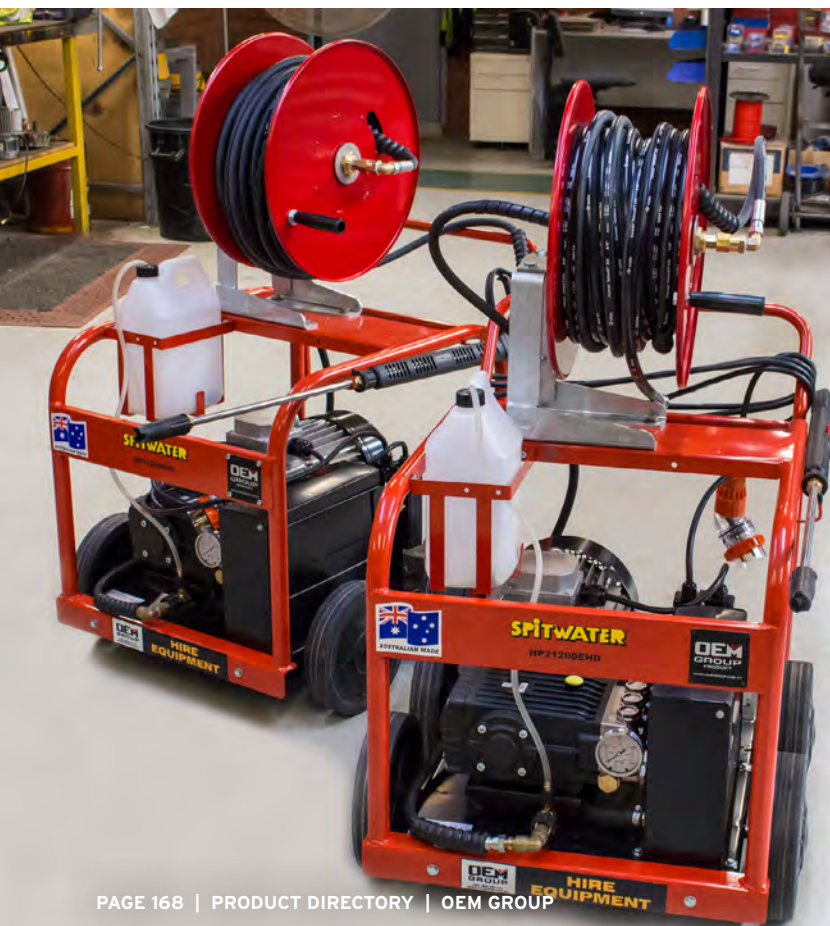



HIRE PLANS

TO SUIT YOUR BUSINESS

CUSTOMISED PROJECTS

Recovery Trailer



Introducing the latest innovation in heavy-vehicle recovery!



SCAN THE
QR CODE TO
WATCH A
VIDEO OF OUR
RECOVERY
TRAILER
IN ACTION

We have revolutionised heavy-vehicle recovery with our latest innovation, the OEM Group Heavy Equipment Recovery Trailer.

The self-contained mobile Recovery Trailer offers a safe and convenient solution for heavy vehicle and equipment recovery.

Custom designed and fabricated at OEM Group's workshop in Western Australia the all-in-one management system is a proven performer in the assisting of mobile heavy-vehicle recovery.

The mobile, heavy-duty unit is built to perfectly suit towing heavy-duty assets and designed to mine specifications for a safe, and speedy recovery of heavy vehicles in any situation.

The trailer is self-contained to store and protect key equipment from the elements and to avoid any potential injury hazards, and features a powerful hydraulic winch, integrated rope, hitch and more.

Flexible Solutions

There are two available designs for the OEM Group Heavy Equipment Recovery Trailer.

The standard design is fitted with a single hydraulic winch while the upgraded design is fitted with two hydraulic winces or can be fitted with a Hiab to eliminate all manual lifting, so the potential for operator injury is significantly reduced.

The powerful, fully integrated, hydraulic winch safely and reliably unspools a massive tow rope for attaching to the equipment. The winch is run by a diesel motor and easily respools the rope for next use. Each trailer is fitted with powerful, battery-operated, work lights for 24/7 operation. Solar Panels on the canopy roof then charge these batteries during the day, saving power.

Each feature on the Recovery Trailer has been designed for safe and effective vehicle recovery, saving manpower and time on-site.

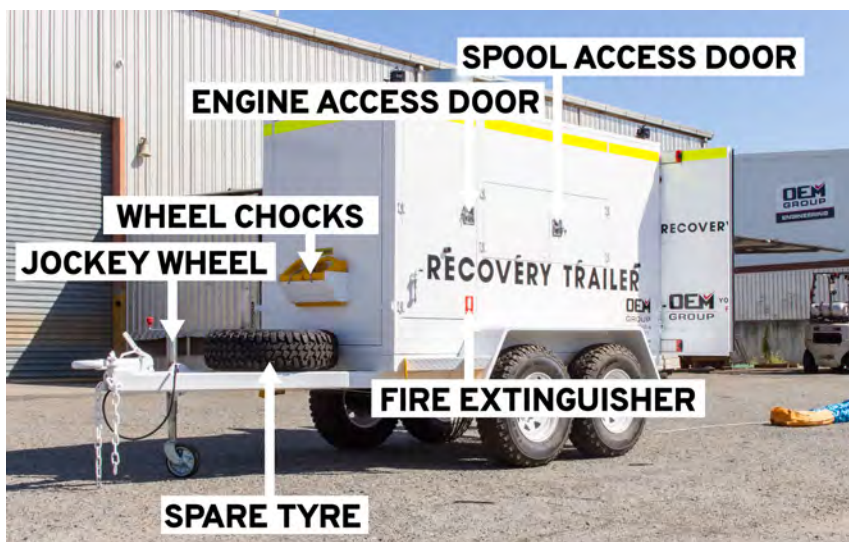
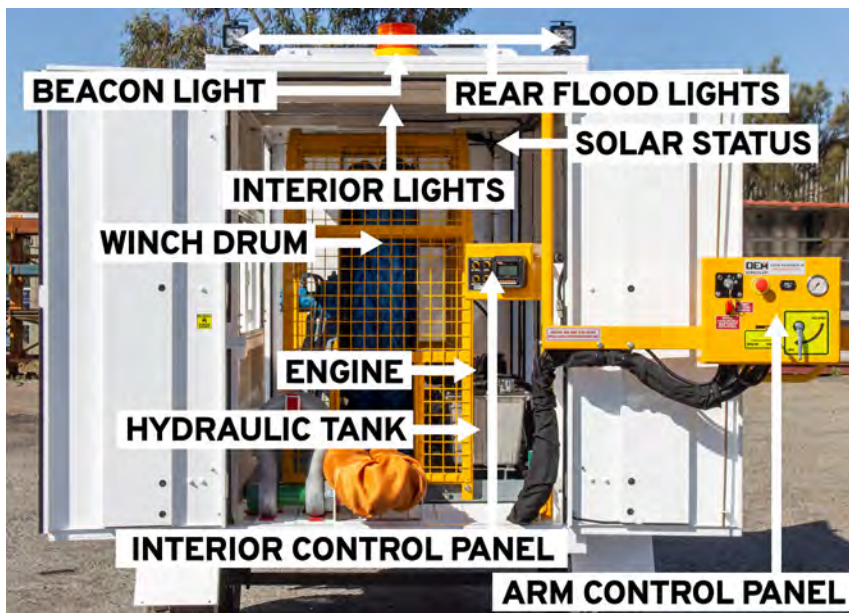

Key Features

- Heavy Duty custom design and fabricated by OEM Group
- All-in-one management system for heavy-duty towing assets
- Self-contained unit with an integrated rope, hitch, hydraulic winch and more
- Protects tow ropes from the outside weather conditions
- Self sufficient with solar panels, batteries and work lights for night recovery
- Designed to meet all mine site specifications
- Proven performer

CUSTOMISED PROJECTS

Specialised FinFan Maintenance Platform

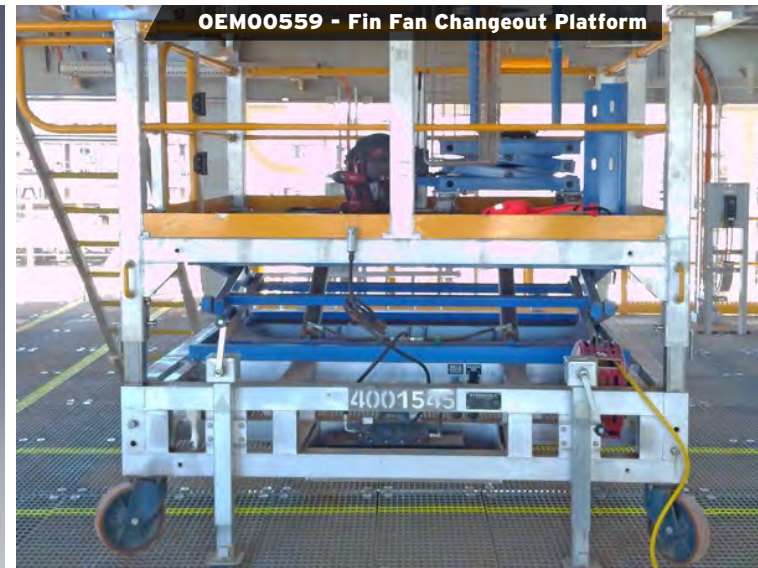

To make money, Oil & Gas needs to be pumping. That's why this major Oil & Gas company asked us to slash their downtime costs.

The Challenge

The maintenance of Fin Fans was the issue - every time this necessary replacement work was done, production stopped and costly scaffolding was erected. To erect and disassemble the scaffolding also added significant time to the job.

The Solution

We designed and built a custom-made platform. The change-over of Fin Fans is now faster, easier, and much safer. The tailor-made platforms - we built 13 of them - are entirely hydraulic and totally compliant with the client's on-plant requirements.

The Benefits

With no need for scaffolding, the operation is much safer and faster - the maintenance workers can position themselves exactly where they need to be. The client is extremely happy; we helped slash days off their operational downtime. Even more, they now own a versatile asset - they've since found a variety of uses for the platform around the site.

CUSTOMISED PROJECTS

Customised Platform For Chute Repairs



In the resources industry, every minute of shutdown lessens profitable output. So when this large iron ore miner needed to minimize downtime, they turned to the experts - the OEM Group.

The Challenge

On this site, changing the wear liners and checking the condition of the main input chute is a regular necessity. However, it's a tricky job and required maintenance workers to set-up complex scaffolding so they could climb down into the chute. The operation was not only very time consuming, it also compromised safety.

The Solution

After talking to the client - listening closely to understand the design concept they had in mind - and then studying the preliminary drawings they supplied, we designed a tailor-made platform that fits perfectly in the chute. Easily craned into position, it fits snugly and safely, giving workers stable and unimpeded access to the wear liners.

The Benefits

A job that once took days - when the assembly and disassembly of the scaffolding was included - now only takes half a day. The workers are extremely happy that the company looked after their welfare and provided a safe and reliable solution. With less downtime, the whole operation spends more time in full operational capacity.

X

E

D

N

E

PART INDEX

OEM

GROUP

YOUR PARTNER IN
PRODUCTIVITY

PART INDEX

Description	Part No	Page	Description	Part No	Page
100T Adjustable Stand	OEM01213	93	Artic Safety Access Platform MODEL A	OEM00623	65
100T Stand Trolley	OEM00896	94	Artic Safety Access Platform MODEL B	OEM00305	65
100T Stillage Stand 1000mm	OEM00502	93	Artic Safety Access Platform MODEL E	OEM00575	66
100T Stillage Stand 550mm	OEM00288	93	Artic Safety Access Platform MODEL F	OEM00934	66
1T Trestle	OEM00582	99	Artic Squat Stands MODEL A	OEM00574	60
1T Trestle	OEM01112	99	Artic Squat Stands MODEL B	OEM01319	60
2 Tier Mining Truck Tray Safety Access Platform MODEL C	OEM00564	44	Assembly Safety Access Platform	OEM00936	67
2 Work Area Radiator Safety Access Platform MODEL E	OEM01255	51	Aviation Chock Trolley	OEM01309	117
2.5T Trestle	OEM00583	99	Aviation Engine Lifting Jig	OEM00098a	117
2.5T Trestle	OEM00595	99	Aviation Engine Lifting Jig	OEM00098b	117
20T Mobile Stand	OEM00395	86	Aviation Maintenance Platform	OEM01236	111
25T Stand 550mm	OEM01346	86	Aviation Rear Wing Access Platform	OEM01034	112
3 Point Safety Access Platform	OEM00276	13	Axle Stand MODEL A	OEM00287	60
50T Adjustable Stand	OEM00767	86	Axle Stand MODEL B	OEM00346	60
50T Jacking Stand	OEM00818	86	Baggage Door Platform	OEM01412	112
55T Jacking Stand 1000mm	OEM00258	89	Belt Splice Safety Access Platform	OEM00414	18
55T Jacking Stand 1320mm	OEM00241	89	Belt Splicing Handrails and Roof Cover	OEM00682	28
55T Jacking Stand 1320mm	OEM00941	89	Belt Splicing Platform	OEM00872	28
55T Jacking Stand 1340mm	OEM00697	89	Belt Splicing Safety Access Platform	OEM00570	18
55T Jacking Stand 1400mm	OEM00240	90	Boom Stand	OEM01224	58
55T Jacking Stand 1500mm	OEM00257	90	Brake Cooling Hose Platform	OEM00687	40
55T Jacking Stand 1580mm	OEM00940	90	Bucket Support Stand	OEM00296	60
55T Jacking Stand 1600mm	OEM00239	90	Bucket Maintenance Platform	OEM01275	59,67
55T Jacking Stand 1700mm	OEM00266	90	Car Dumper Safety Access Platform	OEM00155	20
55T Jacking Stand 1800mm	OEM01334	90	Car Dumper Wear Liner Maintenance Access Platform	OEM01587	27
55T Jacking Stand 2000mm	OEM00267	92	Centre Lift Cylinder Safety Access Platform MODEL C	OEM00800	78
55T Jacking Stand 2100mm	OEM00268	92	Chassis Access Platform	OEM00853	37
55T Jacking Stand 280mm	OEM00265	88	Chassis Handrail MODEL A	OEM00845	36
55T Jacking Stand 350mm	OEM00264	88	Chassis Handrail MODEL B	OEM00846	36
55T Jacking Stand 500mm	OEM00263	88	Chassis Handrail MODEL C	OEM01068	36
55T Jacking Stand 600mm	OEM00262	88	Chassis Handrail MODEL D	OEM00880	37
55T Jacking Stand 700mm	OEM00261	88	Chassis Handrail MODEL E	OEM00522	37
55T Jacking Stand 750mm	OEM00260	88	Chute Cover Safety Access Platform	OEM00416	14
55T Jacking Stand 800mm	OEM00286	89	Chute Feeder Platform	OEM00072	18
55T Jacking Stand 900mm	OEM00259	89	Chute Inspection Safety Access Platform	OEM00398	14
55T Stand Trolley	OEM00840	94	Chute Liner Maintenance Platform	OEM00152	26
750kg Trestle	OEM00581	99	Chute Plug	OEM00091	23
Accumulator Safety Access Platform	OEM01297	39	Chute Screen Platform	OEM00151	25
Air Cleaner Safety Access Platform with Lift	OEM01483	39	Cone Crusher Head Assembly Platform	OEM01547	27
Air Over Hydraulic Trolley	OEM00580	122	Conveyor Roller Trolley	OEM00225	29
Aircraft Engine Hoist	OEM00002	117	Conveyor Roller Trolley	OEM00490	29
Aircraft Maintenance Platform	OEM00024	110	Conveyor Roller Trolley	OEM00789	29
Aircraft Maintenance Work Platform	OEM00001	110	Conveyor Feed Safety Access Platform	OEM00409	16
Aircraft Oil Change Platform	OEM00345	110	Crane Chain Storage	OEM00716a	84
Aircraft Oil Change Platform	OEM01209	111	Crane Maintenance Platform	OEM00963	120
Aircraft Wing Maintenance Platform	OEM01370	111	Crusher Hydroset Oil Tank Safety Access Platform	OEM00642	19
Aluminum Bracket	WC1055 Ali Bracket	103	Crusher Hydroset Oil Tank Safety Access Platform	OEM00643	20
			Crusher Mantle Safety Access Platform	OEM00641	19

PART INDEX

Description	Part No	Page	Description	Part No	Page
Crusher Safety Access Platform	OEM01344	19	Horizontal Steel Plate Rack	OEM00529	96
Cyclone Screen Safety Access Platform	OEM00171	22	Horizontal Steel Rack	OEM00282	96
Diff Skates	OEM00619	60	Horizontal Steel Rack	OEM00742	97
Double Entry Air Cleaner Access Platform MODEL D	OEM00329	39	Hottie IV-D	SHW87/A	155
Draft Arm Stand MODEL D	OEM00939	72	Hottie IV-P	SHW89/A	154
Draft Arm Stand MODEL E	OEM01023	72	Hottie V-D	SHW88/A	155
Drum Floater Sink Screen Safety Access Platform	OEM00170	16	Hottie V-P	SHW90/A	154
Drum Safety Access Platform	OEM00159	16	Hub Stand MODEL A	OEM00735	34
Dual Access Crane Maintenance Platform	OEM00962	120	Hub Stand MODEL B	OEM00897	34
Dual Radiator Safety Access Platform MODEL A	OEM00937	50	Hydraulic Adjustable Platform	OEM00419	59
Elevated Dual Access Crane Maintenance Platform	OEM00964	120	Hydraulic Adjustable Platform	OEM01032	14
Engine Bay Extended Safety Access Platform MODEL B	OEM00539	42	Hydroset Safety Access Platform	OEM00655	24
Engine Bay Left Hand Safety Access Platform MODEL H	OEM00417	75	Mining Truck Tray Safety Access Platform MODEL G	OEM01377	46
Engine Bay Right Hand Safety Access Platform MODEL I	OEM00421	75	Jetfire DC16	JDDI016K	148
Engine Bay Safety Access Platform MODEL D	OEM00460	74	Jetfire DC17	JDDC017K	146
Engine Bay Safety Access Platform MODEL A	OEM00354	42	Jetfire DC30	JDDC030K	146
Engine Bay Safety Access Platform MODEL A	OEM00711	73	Jetfire DC50	JDDC050K	146
Engine Bay Safety Access Platform MODEL B	OEM00770	73	Jetfire DI27	JDDI027K	148
Engine Bay Safety Access Platform MODEL C	OEM00290	73	Jetfire DP105	JDDP105I	147
Engine Bay Safety Access Platform MODEL E	OEM00500	74	Jetfire DP65	JDDP065I	147
Engine Bay Safety Access Platform MODEL F	OEM00710	74	Jetfire IP110	JDIP110	147
Engine Bay Safety Access Platform MODEL G	OEM00768	75	Jetfire IP32	JDIP032I	147
Extended Lift Cylinder Safety Access Platform MODEL A	OEM01077	78	Jetfire J20A	JGDA020I	148
Extra Large Wheelchock	WC1155	102	Jetfire J45A	JGDA045I	148
Feeder Safety Access Platform	OEM00503	22	Large Wheelchock	WC1105	102
Fin Fan Changeout Platform	OEM00559	123	Left Hand Air Cleaner Access Platform MODEL C	OEM00857	38
Fin Fan Changeout Platform	OEM00783	123	Left Hand Wheel End Platform MODEL A	OEM00629	55
Freccia 15 E 38	VS001F	153	Lift Cylinder Access Platform MODEL C	OEM01075	48
Freccia 15 M 38BC	VS002F	153	Lift Cylinder Access Platform MODEL D	OEM00758	49
Freccia 15 M 38BC Long Run	VS003F	153	Lift Cylinder Access Platform MODEL E	OEM01222	49
Freccia 30 M 45 C BC	VS005	153	Lift Cylinder Centre Access Platform MODEL B	OEM01142	48
Front Safety Access Platform MODEL A	OEM00645	76	Lift Cylinder Pin Safety Access Platform	OEM01419	70
Front Safety Access Platform MODEL B	OEM00649	76	Lift Cylinder Safety Access Platform MODEL A	OEM00719	68
Front Safety Access Platform MODEL C	OEM00652	76	Lift Cylinder Safety Access Platform MODEL E	OEM00935	69
Fuel Tank Removal Tool	OEM00245	34	Lift Cylinder Side Access Platform MODEL A	OEM00943	48
Fuel Tank Safety Access Platform	OEM01198	42	Loader Arm Stand MODEL A	OEM00699	61
GPS Calibration Safety Access Platform	OEM01254	40	Loader Arm Stand MODEL B	OEM00750	61
Harvester Belt Lifter	OEM00791	29	Loader Arm Stand MODEL C	OEM00751	61
Heavy Duty Chain Rack	OEM01545	84	Loader Arm Stand MODEL D	OEM01024	61
Heavy Duty Mobile Work Bench	OEM01560	98	Loader Arm Stand MODEL E	OEM00308	62
Heavy Duty Peg Board	OEM01544	84	Loader Arm Stand MODEL F	OEM00231	62
Heavy Duty Work Bench	OEM01548	98	Loader Arm Stand MODEL G	OEM00338	62
Helicopter Maintenance Platform	OEM00150	114	Loader Arm Stand MODEL H	OEM00701	62
Helicopter Maintenance Platform	OEM00271	116	Loader Arm Stand MODEL I	OEM00732	62
Helicopter Maintenance Platform	OEM01274	116	Loader Arm Stand MODEL J	OEM00960	62
Helicopter Maintenance Platform	OEM01404	116	Loader Arm Stand MODEL K	OEM00844	63
Horizontal Plate Rack	OEM00747	97	Loader Assembly Stands	OEM00762	63
			Lockable Crane Chain Storage	OEM00716c	84

PART INDEX

Description	Part No	Page	Description	Part No	Page
Loco Aircon Access Platform	OEM00270	119	Reclaimer Side Safety Access Platform	OEM00227	12
Loco Aircon Access Platform	OEM01031	119	Reclaimer Wheel Inspection Platform	OEM00157	12
Loco Brake Access Platform	OEM01288	119	Return Idler Change Out Safety Access Platform	OEM00459	28
Loco Gen Pod Platform	OEM01195	118	Right Hand Air Cleaner Access Platform MODEL A	OEM00396	38
Loco HVAC Platform	OEM01287	118	Right Hand Lift Cylinder Safety Access Platform MODEL B	OEM00675	78
Loco LSS Access Platform	OEM00876	118	Right Hand Wheel End Platform MODEL B	OEM00635	55
Loco Maintenance Platform	OEM00916	118	Rock Ejector Safety Access Platform	OEM00289	46
Lower Left Hand Artic Safety Access Platform MODEL D	OEM00521	66	Roller Cabinet	OEM00578	85
Lower Right Hand Artic Safety Access Platform MODEL C	OEM00482	65	Roller Changeout Storage Cabinet	OEM01316	29
Lower Tilt Cylinder Safety Access Platform MODEL B	OEM00757	68	Round 45 D 60 BC Chem	VS006FT	153
LRP Safety Access Platform	OEM00156	20	Scalping Screen Safety Access Platform	OEM00563	23
Magnet Trolley	OEM01042	29	Screen Plant Safety Access Platform	OEM00399	22
Maintenance Access Platform	OEM01190	114	Secondary Crusher Bowl Safety Access Platform	OEM00650	24
Maintenance Platform	OEM00090	121	Shelving Unit	OEM00609	100
Mantle Safety Access Platform	OEM00339	23	Shelving Unit	OEM00610	100
Medium Wheelchock	WC1075	102	Ship Loader Scraper Safety Access Platform	OEM01044	24
Mining Truck Multi Level Tool Tray Safety Access Platform MODEL F	OEM01372	46	Single Air Cleaner Access Platform MODEL B	OEM00499	38
Mining Truck Tray 2-Point Inspection Tray Safety Access Platform MODEL A	OEM01039	44	Sizer Maintenance Safety Access Platform	OEM01049	26
Mining Truck Tray Chock	OEM00790	34	Small Wheelchock	WC1055	102
Mining Truck Tray Safety Access Platform MODEL B	OEM00545	44	Spitwater 10-120C	SLD10	132
Mining Truck Tray Safety Access Platform MODEL D	OEM00674	45	Spitwater 10-120H	SLD09	136
Mining Truck Tray Side Mount Tray Safety Access Platform MODEL E	OEM01159	45	Spitwater 13-180H	SLD08	136
Mobile Drum Trolley	OEM00775	85	Spitwater AS12P CF	SP86	152
Mobile Oil Drip Tray	OEM00577	85	Spitwater AS27	SP57	150
Mobile Shelving Unit	OEM00865	100	Spitwater AS400	SP98	150
Mobile Shelving Unit	OEM00900	100	Spitwater AS5	SP45	150
Multi Work Deck Dipper Maintenance Platform	OEM00527	58	Spitwater AS59/CBE	SP77/A	151
Passenger Access Platform	OEM00147	114	Spitwater AS59/M	SP65	151
Product Feeder Safety Access Platform	OEM00560	25	Spitwater AS60 IK	SP78/A	151
Product Screen Rollout Chute Safety Access Platform	OEM00536	25	Spitwater AS600 IK CBM	SP81/A	151
Radiator Safety Access Platform MODEL B	OEM00947	50	Spitwater ASL10	SP55	150
Radiator Safety Access Platform MODEL D	OEM01011	51	Spitwater ASL10	SP55	150
Radiator Safety Access With Work Platform MODEL C	OEM00938	50	Spitwater HC11140P	SLD25	138
Radiator Stand	OEM00423	63	Spitwater HC12180P	SLD24	138
Radiator Stand	OEM00946	34	Spitwater HC15275P	SLD19	138
Rear Brake Access Platform	OEM01403	40	Spitwater HE13200P	SCWA68	138
Rear Pin Safety Access Platform MODEL A	OEM00944	52	Spitwater HE15250P	SCWA67	138
Rear Pin Safety Access Platform MODEL B	OEM00932	52	Spitwater HP10090	SCW76	130
Rear Pin Safety Access Platform MODEL C	OEM01004	52	Spitwater HP110	SCW70	130
Rear Pin Safety Access Platform MODEL D	OEM01252	53	Spitwater HP12110E GT	SCW70/G	131
Rear Safety Access Platform	OEM00644	70	Spitwater HP12150DE	SCWD062	143
Rear Tray Pin Access Platform	OEM01528	53	Spitwater HP151	SCW69	130
Rear Wing Platform	OEM00128	112	Spitwater HP15200E GT	SCW53/G	131
Reclaimer 2-Tier Safety Access Platform	OEM00378	12	Spitwater HP15210DE	SCWD067	143
Reclaimer Bucket Safety Access Platform	OEM00558	13	Spitwater HP201	SCW53	130
Reclaimer Bucket Wheel Safety Access Platform	OEM00554	13	Spitwater HP201/SAE	SCWA62	140
			Spitwater HP201S	SCW54	130
			Spitwater HP2030	SCW85	132
			Spitwater HP21200E GT	SCW54/G	131

PART INDEX

Description	Part No	Page	Description	Part No	Page
Spitwater HP23350DE	SCWD084	144	STEPRITE Minespec Safety Work Access Platform 1750mm	SMP1750	106
Spitwater HP2430/AE	SCWA63	141	STEPRITE Minespec Safety Work Access Platform 2000mm	SMP2000	106
Spitwater HP251/A	SCWA60	140	STEPRITE Minespec Safety Work Access Platform 2250mm	SMP2250	106
Spitwater HP251/AE	SCWA60/A	140	STEPRITE Minespec Safety Work Access Platform 2500mm	SMP2500	106
Spitwater HP251/SAE	SCWA61	141	STEPRITE Minespec Safety Work Access Platform 2750mm	SMP2750	106
Spitwater HP30250DE	SCWD082	144	STEPRITE Minespec Safety Work Access Platform 3000mm	SMP3000	106
Spitwater HP30500E	SCW15	134	Strut Safety Access Platform MODEL A	OEM00633	54
Spitwater HP30600E	SCW17	134	Strut Safety Access Platform MODEL A	OEM10171	49
Spitwater HP3523	SCW86	132	Tilt Cylinder Safety Access Platform MODEL A	OEM00720	67
Spitwater HP3523/AE	SCWA64	141	Tilt Cylinder Safety Access Platform MODEL D	OEM00576	69
Spitwater HP36400E	SCW14	133	Tilt Cylinder Safety Access Platform MODEL F	OEM00945	69
Spitwater HP38500E	SCW19	134	Tilt Cylinder Safety Access Platform with Stairs MODEL C	OEM00489	68
Spitwater HP4025	SCW12	133	Tipper Body Props	OEM00351	126
Spitwater HP47400E	SCW18	133	Tipper Body Props	OEM00352	126
Spitwater HP5015	SCW87	133	Tipper Body Props	OEM00400	126
Spitwater HT1111	SCW82/G	131	Top Fin Fan Maintenance Platform	OEM00556	123
Spitwater HT18160E GT	SCW83/G	131	Train Loadout Height Access Platform	OEM00190	11
Spitwater M26	EX39	152	Train Loadout Inspection Safety Access Platform	OEM00350	11
Spitwater SW110	SHW76-A	137	Train Loadout Safety Access Platform Fixed	OEM00194	10
Spitwater SW151	SHW68	137	Train Loadout Safety End Access Platform	OEM00189	10
Spitwater SW15200DE	SHW87	145	Train Loadout Safety Side Entry Access Platform	OEM00594	10
Spitwater SW15200DES	SHW91	145	Transmission Safety Access Platform MODEL A	OEM00933	54
Spitwater SW15200PE	SHW89	142	Transmission Safety Access Platform MODEL B	OEM00802	54
Spitwater SW201	SHW69	137	Tray Lifting Tool	OEM00303	35
Spitwater SW2021	SHW78	137	Tray Transporter	OEM01349	35
Spitwater SW2030	SHW85	136	TSA15210DET	SCWD067/A	155
Spitwater SW21200DE	SHW88	145	Turbine Trolley	OEM00952	122
Spitwater SW21200PE	SHW90	142	Two Level Dipper Maintenance Platform	OEM00531	58
Spitwater SWC100	SCW11	133	Tyre Inspection Stand	OEM00344	94
Static Transmission Safety Access Platform MODEL B	OEM00851	55	Vertical Plate Rack	OEM00741	96
Steer Cylinder Lifting Jig	OEM01057	34	Vibrating Feeder Safety Access Platform	OEM00647	17
STEPRITE Standard Safety Work Access Platform 500mm	SWP500	106	Vibrating Screen Safety Access Platform	OEM00366	17
STEPRITE Standard Safety Work Access Platform 750mm	SWP750	106	Vibrating Screen Side Safety Access Platform	OEM00374	17
STEPRITE Standard Safety Work Access Platform 1000mm	SWP1000	106	Vibrating Screen Tile Box	OEM01161	28
STEPRITE Standard Safety Work Access Platform 1250mm	SWP1250	106	Vibrating Screen Wear Liner Change Out Safety Access Platform	OEM01299	26
STEPRITE Standard Safety Work Access Platform 1500mm	SWP1500	106	Wash Down Bay Access Platform	OEM01083	127
STEPRITE Standard Safety Work Access Platform 1750mm	SWP1750	106	Wash Down Bay Access Platform	OEM01158	127
STEPRITE Standard Safety Work Access Platform 2000mm	SWP2000	106	Wheel Nut Safety Access Platform MODEL A	OEM01134	56
STEPRITE Standard Safety Work Access Platform 2250mm	SWP2250	106	Wheel Nut Safety Access Platform MODEL B	OEM00805	56
STEPRITE Standard Safety Work Access Platform 2500mm	SWP2500	106	Wheel Nut Safety Access Platform MODEL C	OEM01550	56
STEPRITE Standard Safety Work Access Platform 2750mm	SWP2750	106	Wombat JETTER Trailer	SCWA64/JT	154
STEPRITE Standard Safety Work Access Platform 3000mm	SWP3000	106	Work Bench	OEM00658	98
STEPRITE Minespec Safety Work Access Platform 500mm	SMP500	106	Workmate Hottie	SHW99/A	156
STEPRITE Minespec Safety Work Access Platform 750mm	SMP750	106	Zinc Bracket	WC1075 Zinc Bracket	103
STEPRITE Minespec Safety Work Access Platform 1000mm	SMP1000	106	Zinc Bracket	WC1105 Zinc Bracket	103
STEPRITE Minespec Safety Work Access Platform 1250mm	SMP1250	106	Zinc Bracket	WC1155 Zinc Bracket	103
STEPRITE Minespec Safety Work Access Platform 1500mm	SMP1500	106			



KOMATSU

MSCS
MINE SITE
CONSTRUCTION
SERVICES

STEPRITE



SCS605

600

WLL 180 KG

DEM GROUP

DEM GROUP

PERTH

494 – 498 Great Eastern Highway,
Ascot, WA, 6104

Phone: +61 8 9270 0200

Email: contactoem@oemgroup.com.au

PILBARA

50 Oxide Loop,
Gap Ridge, WA, 6714

Phone: +61 8 9131 5007

Email: contactoem@oemgroup.com.au

www.oemgroup.com.au



YOUR PARTNER IN PRODUCTIVITY.

